

Low saturation voltage type regulator with ON / OFF switch

BA○○ST series

The BA○○ST series are variable, fixed output low drop-out type voltage regulators with an ON / OFF switch. These regulators are used to provide a stabilized output voltage from a fluctuating DC input voltage.

Fixed output voltages are 3V*, 3.3V, 5V, 6V*, 7V, 8V, 9V, 10V, 12V, and 15V*. The maximum current capacity is 1A for each of the above voltages. (Items marked with an asterisk are under development.)

●Applications

Constant voltage power supply

●Features

- 1) Built-in overvoltage protection circuit, overcurrent protection circuit and thermal shutdown circuit.
- 2) TO220FP-5 package can be used in wide range of applications.
- 3) 0 μ A (design value) circuit current when switch is off.
- 4) Richly diverse lineup.
- 5) Low minimum I / O voltage differential.

●Product codes

Output voltage (V)	Product No.	Output voltage (V)	Product No.
Variable	BA00ST*	8.0	BA08ST
3.0	BA03ST*	9.0	BA09ST
3.3	BA033ST	10.0	BA10ST
5.0	BA05ST	12.0	BA12ST
6.0	BA06ST*	15.0	BA15ST*
7.0	BA07ST		

* Under development.

●Absolute maximum ratings (Ta = 25°C)

Parameter	Symbol	Limits	Unit
Power supply voltage	V _{cc}	35	V
Power dissipation	P _d	2000* ¹	mW
Operating temperature	T _{opr}	-40~+85	°C
Storage temperature	T _{stg}	-55~+150	°C
Peak applied voltage	V _{surge}	50* ²	V

*1 Reduced by 16mW for each increase 10To of 1°C over 25°C.

*2 Voltage application time : 200 msec. or less

● Block diagram

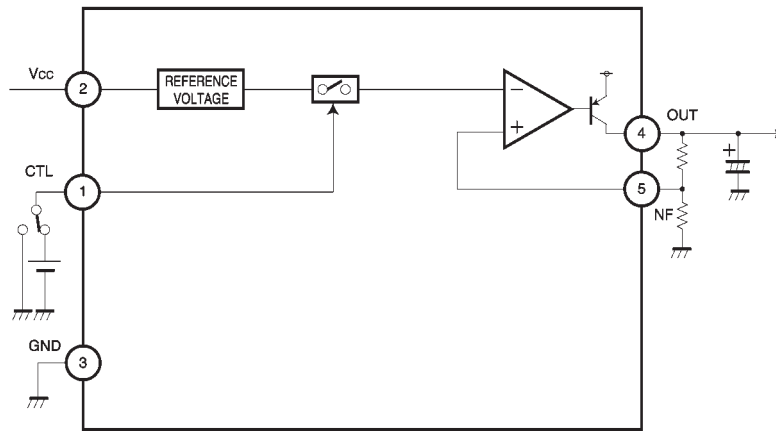

Variable output type (BA00AST)

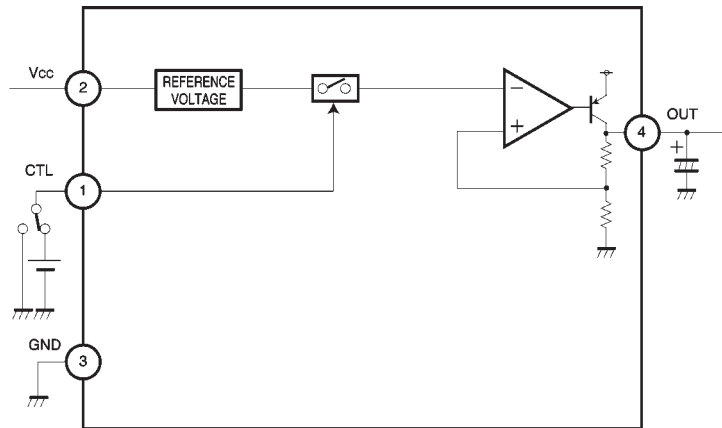

Fixed output type

● Pin descriptions

Pin No.	Pin name	Function
1	CTL	Output ON/OFF
2	V _{CC}	Power supply input
3	GND	Ground
4	OUT	Output
5	C	Reference power supply pin for setting voltage with the BA00ST.
	N.C.	In the BA○○ST Series, these are NC pins, except for the BA00ST.

● Recommended operating conditions

BA00ST

Parameter	Symbol	Min.	Typ.	Max.	Unit
Input voltage	V _{CC}	4	—	25	V
Output current	I _O	—	—	1	A

BA03ST (under development)

Parameter	Symbol	Min.	Typ.	Max.	Unit
Input voltage	V _{CC}	4	—	25	V
Output current	I _O	—	—	1	A

BA033ST

Parameter	Symbol	Min.	Typ.	Max.	Unit
Input voltage	V _{CC}	4.3	—	25	V
Output current	I _O	—	—	1	A

BA05ST

Parameter	Symbol	Min.	Typ.	Max.	Unit
Input voltage	V _{CC}	6	—	25	V
Output current	I _O	—	—	1	A

BA06ST (under development)

Parameter	Symbol	Min.	Typ.	Max.	Unit
Input voltage	V _{CC}	7	—	25	V
Output current	I _O	—	—	1	A

BA07ST

Parameter	Symbol	Min.	Typ.	Max.	Unit
Input voltage	V _{CC}	8	—	25	V
Output current	I _O	—	—	1	A

BA08ST

Parameter	Symbol	Min.	Typ.	Max.	Unit
Input voltage	V _{CC}	9	—	25	V
Output current	I _O	—	—	1	A

BA09ST

Parameter	Symbol	Min.	Typ.	Max.	Unit
Input voltage	V _{CC}	10	—	25	V
Output current	I _O	—	—	1	A

BA10ST

Parameter	Symbol	Min.	Typ.	Max.	Unit
Input voltage	V _{CC}	11	—	25	V
Output current	I _O	—	—	1	A

BA12ST

Parameter	Symbol	Min.	Typ.	Max.	Unit
Input voltage	V _{CC}	13	—	25	V
Output current	I _O	—	—	1	A

BA15ST (under development)

Parameter	Symbol	Min.	Typ.	Max.	Unit
Input voltage	V _{CC}	16	—	25	V
Output current	I _O	—	—	1	A

● Electrical characteristics

BA00ST (unless otherwise noted, Ta = 25°C, Vcc = 10V, Io = 500mA)

Parameter	Symbol	Min.	Typ.	Max.	Unit	Conditions	Measurement circuit
Reference voltage	V _{ref}	1.200	1.225	1.250	V		Fig.1
Power save current	I _{st}	—	0	10	μA	OFF mode	Fig.4
Output voltage	V _o	—	5.0	—	V		Fig.1
Input stability	Reg.I	—	20	100	mV	V _{cc} =6→25V	Fig.1
Ripple rejection ratio	R.R.	45	55	—	dB	⊖ _{IN} =1V _{rms} , f=120Hz, I _o =100mA	Fig.2
Load regulation	Reg.L	—	50	150	mV	I _o =5mA→1A	Fig.1
Temperature coefficient of output voltage	T _{cvo}	—	±0.01	—	% / °C	I _o =5mA, T _j =0~125°C	Fig.1
Minimum I/O voltage differential	V _d	—	0.3	0.5	V	V _{cc} =0.95V _o	Fig.3
Bias current	I _b	—	2.5	5.0	mA	I _o =0mA	Fig.4
Peak output current	I _{o-P}	1.0	1.5	—	A	T _j =25°C	Fig.1
Output short-circuit current	I _{os}	—	0.4	—	A	V _{cc} =25V	Fig.5
ON mode voltage	V _{th1}	2.0	—	—	V	Output Active mode, I _o =0mA	Fig.6
OFF mode voltage	V _{th2}	—	—	0.8	V	Output OFF mode, I _o =0mA	Fig.6
Input high level current	I _{IN}	100	200	300	μA	CTL=5V, I _o =0mA	Fig.6

BA03ST (unless otherwise noted, Ta = 25°C, Vcc = 8V, Io = 500mA) (under development)

Parameter	Symbol	Min.	Typ.	Max.	Unit	Conditions	Measurement circuit
Power save current	I _{st}	—	0	10	μA	OFF mode	Fig.4
Output voltage	V _{O1}	2.85	3.0	3.15	V		Fig.1
Input stability	Reg.I	—	20	100	mV	V _{cc} =4→25V	Fig.1
Ripple rejection ratio	R.R.	45	55	—	dB	⊖ _{IN} =1V _{rms} , f=120Hz, I _o =100mA	Fig.2
Load regulation	Reg.L	—	50	150	mV	I _o =5mA→1A	Fig.1
Temperature coefficient of output voltage	T _{cvo}	—	±0.02	—	% / °C	I _o =5mA, T _j =0~125°C	Fig.1
Minimum I/O voltage differential	V _d	—	0.3	0.5	V	V _{cc} =0.95V _o	Fig.3
Bias current	I _b	—	2.5	5.0	mA	I _o =0mA	Fig.4
Peak output current	I _{o-P}	1.0	1.5	—	A	T _j =25°C	Fig.1
Output short-circuit current	I _{os}	—	0.4	—	A	V _{cc} =25V	Fig.5
ON mode voltage	V _{th1}	2.0	—	—	V	Output Active mode, I _o =0mA	Fig.6
OFF mode voltage	V _{th2}	—	—	0.8	V	Output OFF mode, I _o =0mA	Fig.6
Input high level current	I _{IN}	100	200	300	μA	CTL=5V, I _o =0mA	Fig.6

BA033ST (unless otherwise noted, Ta = 25°C, Vcc = 8V, Io = 500mA)

Parameter	Symbol	Min.	Typ.	Max.	Unit	Conditions	Measurement circuit
Power save current	I _{ST}	—	0	10	μA	OFF mode	Fig.4
Output voltage	V _{O1}	3.13	3.3	3.47	V		Fig.1
Input stability	Reg.I	—	20	100	mV	V _{CC} =4.3→25V	Fig.1
Ripple rejection ratio	R.R.	45	55	—	dB	e _{IN} =1V _{rms} , f=120Hz, I _o =100mA	Fig.2
Load regulation	Reg.L	—	50	150	mV	I _o =5mA→1A	Fig.1
Temperature coefficient of output voltage	T _{CVO}	—	±0.02	—	% / °C	I _o =5mA, T _J =0~125°C	Fig.1
Minimum I/O voltage differential	V _d	—	0.3	0.5	V	V _{CC} =0.95V _o	Fig.3
Bias current	I _b	—	2.5	5.0	mA	I _o =0mA	Fig.4
Peak output current	I _{o-p}	1.0	1.5	—	A	T _J =25°C	Fig.1
Output short-circuit current	I _{os}	—	0.4	—	A	V _{CC} =25V	Fig.5
ON mode voltage	V _{th1}	2.0	—	—	V	Output Active mode, I _o =0mA	Fig.6
OFF mode voltage	V _{th2}	—	—	0.8	V	Output OFF mode, I _o =0mA	Fig.6
Input high level current	I _{IN}	100	200	300	μA	CTL=5V, I _o =0mA	Fig.6

BA05ST (unless otherwise noted, Ta = 25°C, Vcc = 10V, Io = 500mA)

Parameter	Symbol	Min.	Typ.	Max.	Unit	Conditions	Measurement circuit
Power save current	I _{ST}	—	0	10	μA	OFF mode	Fig.4
Output voltage	V _{O1}	4.75	5.0	5.25	V		Fig.1
Input stability	Reg.I	—	20	100	mV	V _{CC} =6→25V	Fig.1
Ripple rejection ratio	R.R.	45	55	—	dB	e _{IN} =1V _{rms} , f=120Hz, I _o =100mA	Fig.2
Load regulation	Reg.L	—	50	150	mV	I _o =5mA→1A	Fig.1
Temperature coefficient of output voltage	T _{CVO}	—	±0.02	—	% / °C	I _o =5mA, T _J =0~125°C	Fig.1
Minimum I/O voltage differential	V _d	—	0.3	0.5	V	V _{CC} =4.75V	Fig.3
Bias current	I _b	—	2.5	5.0	mA	I _o =0mA	Fig.4
Peak output current	I _{o-p}	1.0	1.5	—	A	T _J =25°C	Fig.1
Output short-circuit current	I _{os}	—	0.4	—	A	V _{CC} =25V	Fig.5
ON mode voltage	V _{th1}	2.0	—	—	V	Output Active mode, I _o =0mA	Fig.6
OFF mode voltage	V _{th2}	—	—	0.8	V	Output OFF mode, I _o =0mA	Fig.6
Input high level current	I _{IN}	100	200	300	μA	CTL=5V, I _o =0mA	Fig.6

BA06ST (unless otherwise noted, Ta = 25°C, Vcc = 11V, Io = 500mA) (under development)

Parameter	Symbol	Min.	Typ.	Max.	Unit	Conditions	Measurement circuit
Power save current	I _{ST}	—	0	10	μA	OFF mode	Fig.4
Output voltage	V _{O1}	5.7	6.0	6.3	V		Fig.1
Input stability	Reg.I	—	20	100	mV	V _{CC} =7→25V	Fig.1
Ripple rejection ratio	R.R.	45	55	—	dB	⊖ _{IN} =1V _{rms} , f=120Hz, I _o =100mA	Fig.2
Load regulation	Reg.L	—	50	150	mV	I _o =5mA→1A	Fig.1
Temperature coefficient of output voltage	T _{CV0}	—	±0.02	—	% / °C	I _o =5mA, T _J =0~125°C	Fig.1
Minimum I/O voltage differential	V _d	—	0.3	0.5	V	V _{CC} =5.7V	Fig.3
Bias current	I _b	—	2.5	5.0	mA	I _o =0mA	Fig.4
Peak output current	I _{o-P}	1.0	1.5	—	A	T _J =25°C	Fig.1
Output short-circuit current	I _{os}	—	0.4	—	A	V _{CC} =25V	Fig.5
ON mode voltage	V _{th1}	2.0	—	—	V	Output Active mode, I _o =0mA	Fig.6
OFF mode voltage	V _{th2}	—	—	0.8	V	Output OFF mode, I _o =0mA	Fig.6
Input high level current	I _{IN}	100	200	300	μA	CTL=5V, I _o =0mA	Fig.6

BA07ST (unless otherwise noted, Ta = 25°C, Vcc = 12V, Io = 500mA)

Parameter	Symbol	Min.	Typ.	Max.	Unit	Conditions	Measurement circuit
Power save current	I _{ST}	—	0	10	μA	OFF mode	Fig.4
Output voltage	V _{O1}	6.65	7.0	7.35	V		Fig.1
Input stability	Reg.I	—	20	100	mV	V _{CC} =8→25V	Fig.1
Ripple rejection ratio	R.R.	45	55	—	dB	⊖ _{IN} =1V _{rms} , f=120Hz, I _o =100mA	Fig.2
Load regulation	Reg.L	—	50	150	mV	I _o =5mA→1A	Fig.1
Temperature coefficient of output voltage	T _{CV0}	—	±0.02	—	% / °C	I _o =5mA, T _J =0~125°C	Fig.1
Minimum I/O voltage differential	V _d	—	0.3	0.5	V	V _{CC} =6.65V	Fig.3
Bias current	I _b	—	2.5	5.0	mA	I _o =0mA	Fig.4
Peak output current	I _{o-P}	1.0	1.5	—	A	T _J =25°C	Fig.1
Output short-circuit current	I _{os}	—	0.4	—	A	V _{CC} =25V	Fig.5
ON mode voltage	V _{th1}	2.0	—	—	V	Output Active mode, I _o =0mA	Fig.6
OFF mode voltage	V _{th2}	—	—	0.8	V	Output OFF mode, I _o =0mA	Fig.6
Input high level current	I _{IN}	100	200	300	μA	CTL=5V, I _o =0mA	Fig.6

BA08ST (unless otherwise noted, $T_a = 25^\circ\text{C}$, $V_{CC} = 13\text{V}$, $I_o = 500\text{mA}$)

Parameter	Symbol	Min.	Typ.	Max.	Unit	Conditions	Measurement circuit
Power save current	I_{ST}	—	0	10	μA	OFF mode	Fig.4
Output voltage	V_{O1}	7.6	8.0	8.4	V		Fig.1
Input stability	Reg.I	—	20	100	mV	$V_{CC}=9\rightarrow 25\text{V}$	Fig.1
Ripple rejection ratio	R.R.	45	55	—	dB	$\Theta_{IN}=1V_{rms}$, $f=120\text{Hz}$, $I_o=100\text{mA}$	Fig.2
Load regulation	Reg.L	—	50	150	mV	$I_o=5\text{mA}\rightarrow 1\text{A}$	Fig.1
Temperature coefficient of output voltage	T_{CVO}	—	± 0.02	—	$\% / ^\circ\text{C}$	$I_o=5\text{mA}$, $T_j=0\sim 125^\circ\text{C}$	Fig.1
Minimum I/O voltage differential	V_d	—	0.3	0.5	V	$V_{CC}=0.95V_o$	Fig.3
Bias current	I_b	—	2.5	5.0	mA	$I_o=0\text{mA}$	Fig.4
Peak output current	I_{o-P}	1.0	1.5	—	A	$T_j=25^\circ\text{C}$	Fig.1
Output short-circuit current	I_{os}	—	0.4	—	A	$V_{CC}=25\text{V}$	Fig.5
ON mode voltage	V_{th1}	2.0	—	—	V	Output Active mode, $I_o=0\text{mA}$	Fig.6
OFF mode voltage	V_{th2}	—	—	0.8	V	Output OFF mode, $I_o=0\text{mA}$	Fig.6
Input high level current	I_{IN}	100	200	300	μA	$CTL=5\text{V}$, $I_o=0\text{mA}$	Fig.6

BA09ST (unless otherwise noted, $T_a = 25^\circ\text{C}$, $V_{CC} = 14\text{V}$, $I_o = 500\text{mA}$)

Parameter	Symbol	Min.	Typ.	Max.	Unit	Conditions	Measurement circuit
Power save current	I_{ST}	—	0	10	μA	OFF mode	Fig.4
Output voltage	V_{O1}	8.55	9.0	9.45	V		Fig.1
Input stability	Reg.I	—	20	100	mV	$V_{CC}=10\rightarrow 25\text{V}$	Fig.1
Ripple rejection ratio	R.R.	45	55	—	dB	$\Theta_{IN}=1V_{rms}$, $f=120\text{Hz}$, $I_o=100\text{mA}$	Fig.2
Load regulation	Reg.L	—	50	150	mV	$I_o=5\text{mA}\rightarrow 1\text{A}$	Fig.1
Temperature coefficient of output voltage	T_{CVO}	—	± 0.02	—	$\% / ^\circ\text{C}$	$I_o=5\text{mA}$, $T_j=0\sim 125^\circ\text{C}$	Fig.1
Minimum I/O voltage differential	V_d	—	0.3	0.5	V	$V_{CC}=0.95V_o$	Fig.3
Bias current	I_b	—	2.5	5.0	mA	$I_o=0\text{mA}$	Fig.4
Peak output current	I_{o-P}	1.0	1.5	—	A	$T_j=25^\circ\text{C}$	Fig.1
Output short-circuit current	I_{os}	—	0.4	—	A	$V_{CC}=25\text{V}$	Fig.5
ON mode voltage	V_{th1}	2.0	—	—	V	Output Active mode, $I_o=0\text{mA}$	Fig.6
OFF mode voltage	V_{th2}	—	—	0.8	V	Output OFF mode, $I_o=0\text{mA}$	Fig.6
Input high level current	I_{IN}	100	200	300	μA	$CTL=5\text{V}$, $I_o=0\text{mA}$	Fig.6

BA10ST (unless otherwise noted, Ta = 25°C, Vcc = 15V, Io = 500mA)

Parameter	Symbol	Min.	Typ.	Max.	Unit	Conditions	Measurement circuit
Power save current	I _{ST}	—	0	10	μA	OFF mode	Fig.4
Output voltage	V _{O1}	9.5	10	10.5	V		Fig.1
Input stability	Reg.I	—	20	100	mV	V _{CC} =11→25V	Fig.1
Ripple rejection ratio	R.R.	45	55	—	dB	E _{IN} =1V _{rms} , f=120Hz, I _o =100mA	Fig.2
Load regulation	Reg.L	—	50	150	mV	I _o =5mA→1A	Fig.1
Temperature coefficient of output voltage	T _{CV0}	—	±0.02	—	% / °C	I _o =5mA, T _j =0~125°C	Fig.1
Minimum I/O voltage differential	V _d	—	0.3	0.5	V	V _{CC} =0.95V _o	Fig.3
Bias current	I _b	—	2.5	5.0	mA	I _o =0mA	Fig.4
Peak output current	I _{o-P}	1.0	1.5	—	A	T _j =25°C	Fig.1
Output short-circuit current	I _{os}	—	0.4	—	A	V _{CC} =25V	Fig.5
ON mode voltage	V _{th1}	2.0	—	—	V	Output Active mode, I _o =0mA	Fig.6
OFF mode voltage	V _{th2}	—	—	0.8	V	Output OFF mode, I _o =0mA	Fig.6
Input high level current	I _{IN}	100	200	300	μA	CTL=5V, I _o =0mA	Fig.6

BA12ST (unless otherwise noted, Ta = 25°C, Vcc = 17V, Io = 500mA)

Parameter	Symbol	Min.	Typ.	Max.	Unit	Conditions	Measurement circuit
Power save current	I _{ST}	—	0	10	μA	OFF mode	Fig.4
Output voltage	V _{O1}	11.4	12	12.6	V		Fig.1
Input stability	Reg.I	—	20	100	mV	V _{CC} =13→25V	Fig.1
Ripple rejection ratio	R.R.	45	55	—	dB	E _{IN} =1V _{rms} , f=120Hz, I _o =100mA	Fig.2
Load regulation	Reg.L	—	50	150	mV	I _o =5mA→1A	Fig.1
Temperature coefficient of output voltage	T _{CV0}	—	±0.02	—	% / °C	I _o =5mA, T _j =0~125°C	Fig.1
Minimum I/O voltage differential	V _d	—	0.3	0.5	V	V _{CC} =0.95V _o	Fig.3
Bias current	I _b	—	2.5	5.0	mA	I _o =0mA	Fig.4
Peak output current	I _{o-P}	1.0	1.5	—	A	T _j =25°C	Fig.1
Output short-circuit current	I _{os}	—	0.4	—	A	V _{CC} =25V	Fig.5
ON mode voltage	V _{th1}	2.0	—	—	V	Output Active mode, I _o =0mA	Fig.6
OFF mode voltage	V _{th2}	—	—	0.8	V	Output OFF mode, I _o =0mA	Fig.6
Input high level current	I _{IN}	100	200	300	μA	CTL=5V, I _o =0mA	Fig.6

BA15ST (unless otherwise noted, $T_a = 25^\circ\text{C}$, $V_{CC} = 20\text{V}$, $I_o = 500\text{mA}$) (under development)

Parameter	Symbol	Min.	Typ.	Max.	Unit	Conditions	Measurement circuit
Power save current	I_{ST}	—	0	10	μA	OFF mode	Fig.4
Output voltage	V_{O1}	14.25	15	15.75	V		Fig.1
Input stability	Reg.I	—	20	100	mV	$V_{CC}=16\rightarrow 25\text{V}$	Fig.1
Ripple rejection ratio	R.R.	45	55	—	dB	$e_{IN}=1\text{V}_{rms}$, $f=120\text{Hz}$, $I_o=100\text{mA}$	Fig.2
Load regulation	Reg.L	—	50	150	mV	$I_o=5\text{mA}\rightarrow 1\text{A}$	Fig.1
Temperature coefficient of output voltage	T_{CVO}	—	± 0.02	—	$\% / ^\circ\text{C}$	$I_o=5\text{mA}$, $T_j=0\sim 125^\circ\text{C}$	Fig.1
Minimum I/O voltage differential	V_d	—	0.3	0.5	V	$V_{CC}=0.95V_o$	Fig.3
Bias current	I_b	—	2.5	5.0	mA	$I_o=0\text{mA}$	Fig.4
Peak output current	I_{O-P}	1.0	1.5	—	A	$T_j=25^\circ\text{C}$	Fig.1
Output short-circuit current	I_{OS}	—	0.4	—	A	$V_{CC}=25\text{V}$	Fig.5
ON mode voltage	V_{th1}	2.0	—	—	V	Output Active mode, $I_o=0\text{mA}$	Fig.6
OFF mode voltage	V_{th2}	—	—	0.8	V	Output OFF mode, $I_o=0\text{mA}$	Fig.6
Input high level current	I_{IN}	100	200	300	μA	$CTL=5\text{V}$, $I_o=0\text{mA}$	Fig.6

● Measurement circuits

(The C pin only exists on the BA00AST, For the BA00AST, place a 6.8 kΩ resistor between the OUT and C pins, and a 2.2 kΩ resistor between the C and GND pins.)

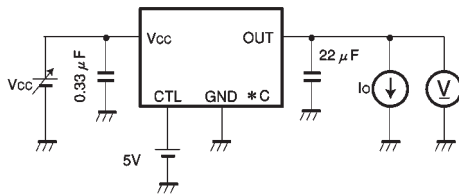
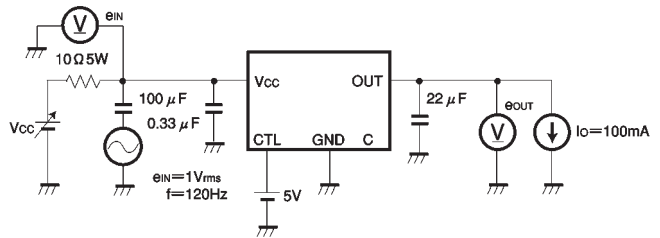

Fig.1 Measurement circuit for output voltage, input stability, load regulation, and temperature coefficient of output voltage



$$\text{Ripple rejection ratio R.R.} = 20 \log \left(\frac{e_{IN}}{e_{OUT}} \right)$$

Fig.2 Measurement circuit for ripple rejection ratio

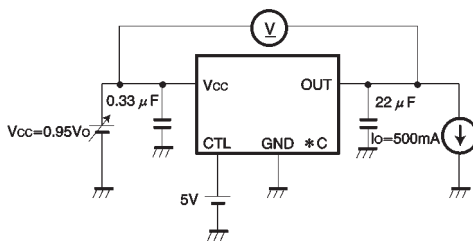

Fig.3 Measurement circuit for minimum I/O voltage differential

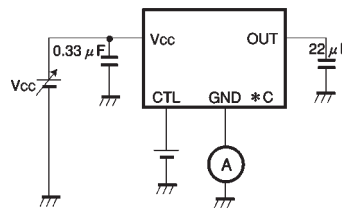

Fig.4 Measurement circuit for bias current, power save current measurement circuit

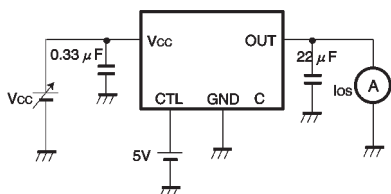

Fig.5 Measurement circuit for output short-circuit current

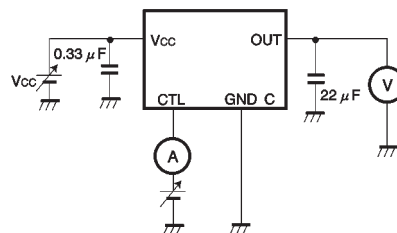

Fig.6 Measurement circuit for ON/OFF mode voltage, input high level current

● Operation notes**(1) Operating power supply voltage**

When operating within the normal voltage range and within the ambient operating temperature range, most circuit functions are guaranteed. The rated values cannot be guaranteed for the electrical characteristics, but there are no sudden changes of the characteristics within these ranges.

(2) Power dissipation

Heat attenuation characteristics are noted on a separate page and can be used as a guide in judging power dissipation.

If these ICs are used in such a way that the allowable power dissipation level is exceeded, an increase in the chip temperature could cause a reduction in the current capability or could otherwise adversely affect the performance of the IC. Make sure a sufficient margin is allowed so that the allowable power dissipation value is not exceeded.

(3) Output oscillation prevention and bypass capacitor
Be sure to connect a capacitor between the output pin and GND to prevent oscillation. Since fluctuations in the value of the capacitor due to temperature changes may cause oscillations, a tantalum electrolytic capacitor with a small internal series resistance (ESR) is recommended.

A 22 μ F capacitor is recommended; however, be aware that if an extremely large capacitance is used (1000 μ F or greater), then oscillations may occur at low frequencies. Therefore, be sure to perform the appropriate verifications before selecting the capacitor.

Also, we recommend connecting a 0.33 μ F bypass capacitor as close as possible between the input pin and GND.

(4) Current overload protection circuit

A current overload protection circuit is built into the out-

puts, to prevent IC destruction if the load is shorted.

This protection circuit limits the current in the shape of a '7'. It is designed with a high margin, so that even if a large current suddenly flows through the large capacitor in the IC, the current is restricted and latching is prevented.

However, these protection circuits are only good for preventing damage from sudden accidents. The design should take this into consideration, so that the protection circuit is not made to operate continuously (for instance, clamping at an output of 1V_F or greater; below 1V_F, the short mode circuit operates). Note that the capacitor has negative temperature characteristics, and the design should take this into consideration.

(5) Thermal overload circuit

A built-in thermal overload circuit prevents damage from overheating. When the thermal circuit is activated, the various outputs are in the OFF state. When the temperature drops back to a constant level, the circuit is restored.

(6) Internal circuits could be damaged if there are modes in which the electric potential of the application's input (V_{CC}) and GND are the opposite of the electric potential of the various outputs. Use of a diode or other such bypass path is recommended.

(7) Although the manufacture of this product includes rigorous quality assurance procedures, the product may be damaged if absolute maximum ratings for voltage or operating temperature are exceeded. If damage has occurred, special modes (such as short circuit mode or open circuit mode) cannot be specified. If it is possible that such special modes may be needed, please consider using a fuse or some other mechanical safety measure.

(8) When used within a strong magnetic field, be aware that there is a slight possibility of malfunction.

●Electrical characteristic curves

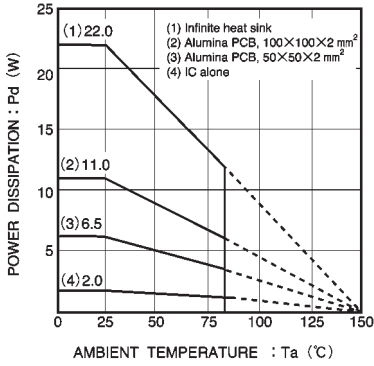

Fig. 7 Ambient temperature vs power dissipation characteristics

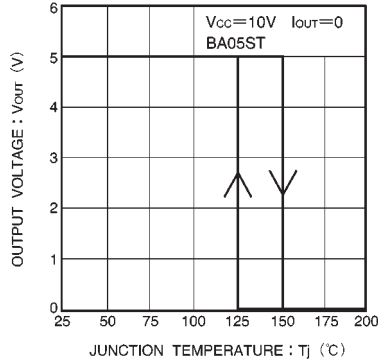

Fig. 8 Thermal cutoff circuit characteristics

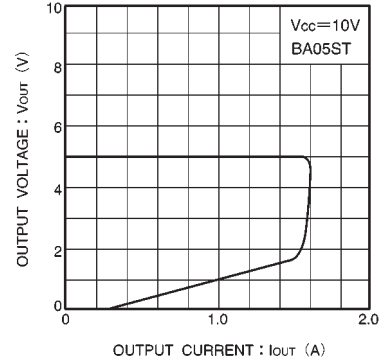

Fig. 9 Current limit characteristics

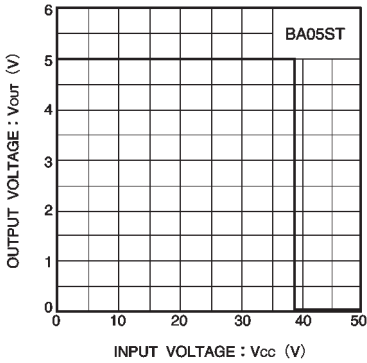
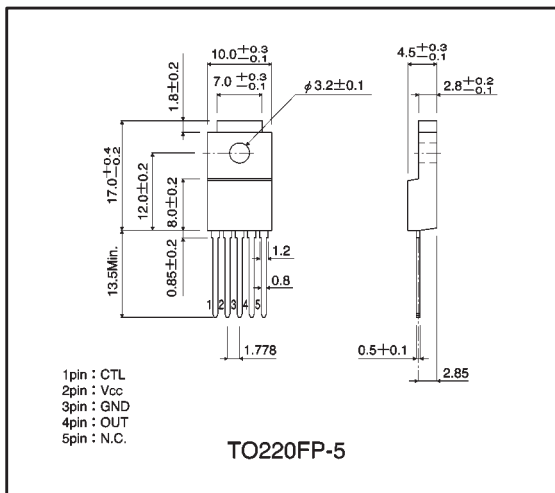

Fig. 10 Over voltage protection characteristics

●External dimensions (Units: mm)



Notes

- No technical content pages of this document may be reproduced in any form or transmitted by any means without prior permission of ROHM CO.,LTD.
- The contents described herein are subject to change without notice. The specifications for the product described in this document are for reference only. Upon actual use, therefore, please request that specifications to be separately delivered.
- Application circuit diagrams and circuit constants contained herein are shown as examples of standard use and operation. Please pay careful attention to the peripheral conditions when designing circuits and deciding upon circuit constants in the set.
- Any data, including, but not limited to application circuit diagrams information, described herein are intended only as illustrations of such devices and not as the specifications for such devices. ROHM CO.,LTD. disclaims any warranty that any use of such devices shall be free from infringement of any third party's intellectual property rights or other proprietary rights, and further, assumes no liability of whatsoever nature in the event of any such infringement, or arising from or connected with or related to the use of such devices.
- Upon the sale of any such devices, other than for buyer's right to use such devices itself, resell or otherwise dispose of the same, no express or implied right or license to practice or commercially exploit any intellectual property rights or other proprietary rights owned or controlled by
- ROHM CO., LTD. is granted to any such buyer.
- Products listed in this document use silicon as a basic material.
Products listed in this document are no antiradiation design.

The products listed in this document are designed to be used with ordinary electronic equipment or devices (such as audio visual equipment, office-automation equipment, communications devices, electrical appliances and electronic toys).

Should you intend to use these products with equipment or devices which require an extremely high level of reliability and the malfunction of which would directly endanger human life (such as medical instruments, transportation equipment, aerospace machinery, nuclear-reactor controllers, fuel controllers and other safety devices), please be sure to consult with our sales representative in advance.

About Export Control Order in Japan

Products described herein are the objects of controlled goods in Annex 1 (Item 16) of Export Trade Control Order in Japan.

In case of export from Japan, please confirm if it applies to "objective" criteria or an "informed" (by MITI clause) on the basis of "catch all controls for Non-Proliferation of Weapons of Mass Destruction.