

# 35V MAX 1A Output LDO Regulator

## BA□□CC0WFP/WT(-V5)

## BA□□CC0FP/T

### ● Description

BA□□CC0WFP/WT(-V5) and BA□□CC0FP/T are PNP output LDO regulator ICs with the output current of 1A and a voltage accuracy of  $\pm 2\%$ . This IC has incorporated over-current protection circuit, over-voltage protection circuit and thermal protection circuit. BA□□CC0WFP/WT(-V5) also incorporates shutdown switch to control output ON/OFF. This IC is perfect for applications with high-voltage requirements, power supply applications.

[Series line-up]

Part No.	Output Current (A)	Output Voltage(V)								Package		
BA□□CC0WFP	1.0	-	3.3	5	6	7	8	9	-	-	TO252-5	
BA□□CC0WT		3	3.3	5	-	7	8	9	10	12	TO220FP-5	
BA□□CC0WT(-V5)		-	3.3	5	-	-	8	9	-	12	TO220FP-5(V5)	
BA□□CC0FP		3	3.3	5	6	7	8	9	10	12	15	TO252-3
BA□□CC0T		3	3.3	5	-	7	8	9	10	12	15	TO220FP

### ● Features

- 1) Maximum output current : 1A
- 2) Output voltage accuracy :  $\pm 2\%$
- 3) Low drop-out voltage type with PNP output
- 4) 35V high-voltage process
- 5) Built-in over-voltage protection circuit, over-current protection circuit, thermal protection circuit
- 6) Built-in shutdown circuit which circuit current is 0uA.  
(BA□□CC0WFP/WT(-V5))
- 7) Two types of package (Small mounting type and insertion type)

### Applications

Consumer products

### ● Absolute Maximum Ratings (Ta=25°C)

Parameter	Symbol	Limits	Unit
Supply Voltage	VCC	-0.3 ~ +35 *1	V
Output Pin Control Voltage	VCTL	-0.3 ~ +VCC	V
Power Dissipation	Pd	1200	*2
		1300	*3
		2000	*4
		2000	*4
Operating Temperature Range	Topr	-40 ~ +125	°C
Storage Temperature Range	Tstg	-55 ~ +150	°C
Junction Temperature	Tjmax	150	°C
Peak Supply Voltage	VCC peak	50	*5 V

\*1 Do not however exceed Pd.

\*2 Mounted on 70mm x 70mm x 1.6mm glass-epoxy PCB Derating in done at 9.6mW/°C for operating above Ta=25°C

\*3 Mounted on 70mm x 70mm x 1.6mm glass-epoxy PCB Derating in done at 10.4mW/°C for operating above Ta=25°C

\*4 Mounted on 70mm x 70mm x 1.6mm glass-epoxy PCB Derating in done at 10.4mW/°C for operating above Ta=25°C

\*5 Bias voltage in 200msec(tr<sub>r</sub>≥1msec).

### ● Dimension (Units :mm)

BA□□CC0WFP



TO252-5

BA□□CC0WT

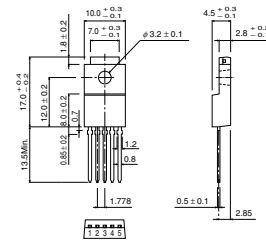

TO220FP-5

BA□□CC0WT(-V5)

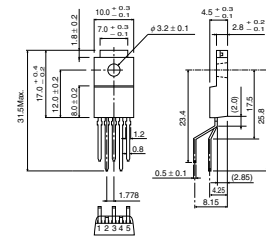

TO220FP-5(V5)

BA□□CC0FP



TO252-3

BA□□CC0T

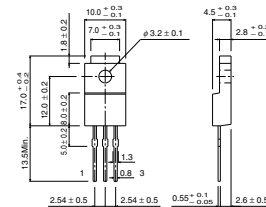

TO220FP

[BA□□CC0WFP/WT(-V5)]

● Electrical Characteristics (Unless otherwise specified, Ta=25°C, Vcc=(Vo+5)V, Io=500mA)

Parameter	Symbol	Min.	Typ.	Max.	Unit	Conditions
Output voltage	Vo	0.98 x Vo	Vo	1.02 x Vo	V	Vo : Refer to the series line-up
Shut down current	I <sub>sd</sub>	-	0	10	μA	V <sub>CTL</sub> =0V
Bias current	I <sub>b</sub>	-	2.5	5.0	mA	V <sub>CTL</sub> =2V, I <sub>o</sub> =0mA
Dropout voltage	ΔV <sub>d</sub>	-	0.3	0.5	V	V <sub>cc</sub> =0.95Vo
Peak output current	I <sub>o</sub>	1.0	-	-	A	
Ripple rejection	R.R.	45	55	-	dB	f=120Hz, e <sub>in</sub> =1V <sub>rms</sub> , I <sub>o</sub> =100mA
Line regulation	Reg.I	-	20	100	mV	V <sub>cc</sub> =(Vo+1)V → 25V
Load regulation	Reg.L	-	50	150	mV	I <sub>o</sub> =5mA → 1A
Temperature coefficient of output current *	T <sub>cvo</sub>	-	±0.02	-	% / °C	I <sub>o</sub> =5mA, T <sub>j</sub> =0~125°C
Output short current	I <sub>os</sub>	-	0.4	-	A	V <sub>cc</sub> =25V
ON mode voltage	V <sub>thH</sub>	2.0	-	-	V	ACTIVE MODE, I <sub>o</sub> =0mA
OFF mode voltage	V <sub>thL</sub>	-	-	0.8	V	OFF MODE, I <sub>o</sub> =0mA
Input high current	I <sub>ctl</sub>	100	200	300	μA	V <sub>CTL</sub> =5V, I <sub>o</sub> =0mA

\* Designed Guarantee.(Outgoing inspection is not done all products.)

[BA□□CC0FP/T]

● Electrical Characteristics (Unless otherwise specified, Ta=25°C, Vcc=(Vo+5)V, Io=500mA)

Parameter	Symbol	Min.	Typ.	Max.	Unit	Conditions
Output voltage	Vo	0.98 x Vo	Vo	1.02 x Vo	V	Vo : Refer to the series line-up
Bias current	I <sub>b</sub>	-	2.5	5.0	mA	ACTIVE MODE, I <sub>o</sub> =0mA
Dropout voltage	ΔV <sub>d</sub>	-	0.3	0.5	V	V <sub>cc</sub> =0.95Vo
Peak output current	I <sub>o</sub>	1.0	-	-	A	
Ripple rejection	R.R.	45	55	-	dB	f=120Hz, e <sub>in</sub> =1V <sub>rms</sub> , I <sub>o</sub> =100mA
Line regulation	Reg.I	-	20	100	mV	V <sub>cc</sub> =(Vo+1)V → 25V
Load regulation	Reg.L	-	50	150	mV	I <sub>o</sub> =5mA → 1A
Temperature coefficient of output current *	T <sub>cvo</sub>	-	±0.02	-	% / °C	I <sub>o</sub> =5mA, T <sub>j</sub> =0~125°C
Output short current	I <sub>os</sub>	-	0.4	-	A	V <sub>cc</sub> =25V

\* Designed Guarantee.(Outgoing inspection is not done all products.)

● Application Circuit

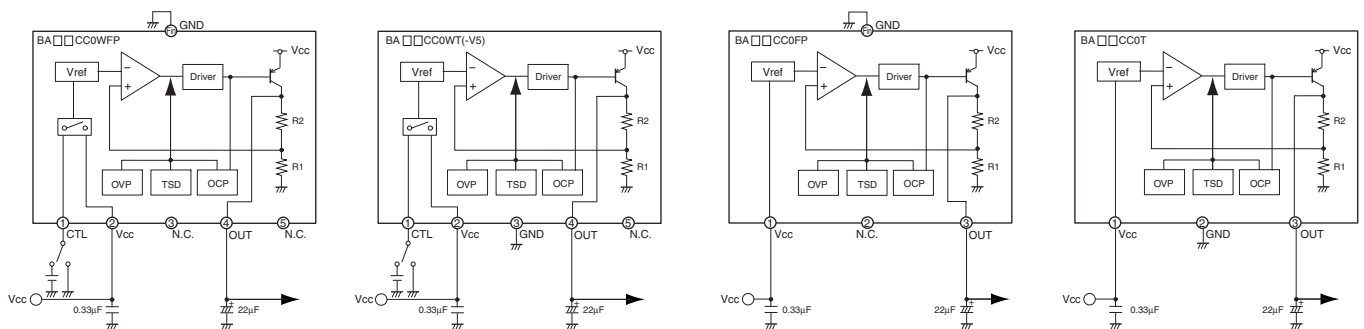

### Notes

- No technical content pages of this document may be reproduced in any form or transmitted by any means without prior permission of ROHM CO.,LTD.
- The contents described herein are subject to change without notice. The specifications for the product described in this document are for reference only. Upon actual use, therefore, please request that specifications to be separately delivered.
- Application circuit diagrams and circuit constants contained herein are shown as examples of standard use and operation. Please pay careful attention to the peripheral conditions when designing circuits and deciding upon circuit constants in the set.
- Any data, including, but not limited to application circuit diagrams information, described herein are intended only as illustrations of such devices and not as the specifications for such devices. ROHM CO.,LTD. disclaims any warranty that any use of such devices shall be free from infringement of any third party's intellectual property rights or other proprietary rights, and further, assumes no liability of whatsoever nature in the event of any such infringement, or arising from or connected with or related to the use of such devices.
- Upon the sale of any such devices, other than for buyer's right to use such devices itself, resell or otherwise dispose of the same, no express or implied right or license to practice or commercially exploit any intellectual property rights or other proprietary rights owned or controlled by
- ROHM CO., LTD. is granted to any such buyer.
- Products listed in this document use silicon as a basic material.  
Products listed in this document are no antiradiation design.

The products listed in this document are designed to be used with ordinary electronic equipment or devices (such as audio visual equipment, office-automation equipment, communications devices, electrical appliances and electronic toys).

Should you intend to use these products with equipment or devices which require an extremely high level of reliability and the malfunction of which would directly endanger human life (such as medical instruments, transportation equipment, aerospace machinery, nuclear-reactor controllers, fuel controllers and other safety devices), please be sure to consult with our sales representative in advance.

#### About Export Control Order in Japan

Products described herein are the objects of controlled goods in Annex 1 (Item 16) of Export Trade Control Order in Japan.

In case of export from Japan, please confirm if it applies to "objective" criteria or an "informed" (by MITI clause) on the basis of "catch all controls for Non-Proliferation of Weapons of Mass Destruction.