

- Monolithic Silicon IC Containing Photodiode, Operational Amplifier, and Feedback Components
- Converts Light Intensity to a Voltage
- Irradiance Responsivity, Typically  $9 \text{ mV}/(\mu\text{W}/\text{cm}^2)$  at  $\lambda_p = 635 \text{ nm}$
- Compact 3-Lead Clear Plastic Package
- Single Voltage Supply Operation
- Low Dark (Offset) Voltage....10 mV Max
- Low Supply Current.....1.1 mA Typical
- Wide Supply-Voltage Range.... 2.7 V to 5.5 V
- Replacement for TSL254
- RoHS Compliant (–LF Package Only)

**PACKAGE S**  
**SIDELOOKER**  
**(FRONT VIEW)**

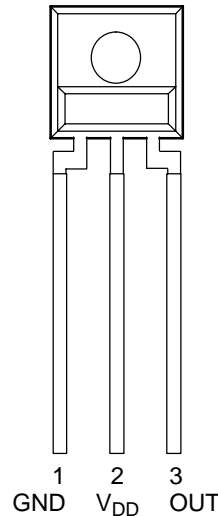

**PACKAGE SM**  
**SURFACE MOUNT**  
**SIDELOOKER**  
**(FRONT VIEW)**

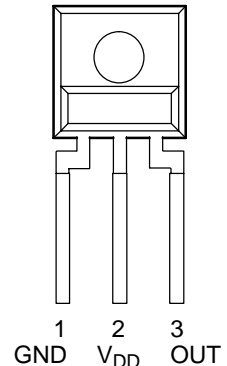

## Description

The TSL254R is a light-to-voltage optical sensor combining a photodiode and a transimpedance amplifier (feedback resistor = 1 MΩ) on a single monolithic IC. Output voltage is directly proportional to the light intensity (irradiance) on the photodiode. The device has improved amplifier offset-voltage stability and low power consumption and is supplied in a 3-lead clear plastic sidelooker package with an integral lens. When supplied in the lead (Pb) free package, the device is RoHS compliant.

## Functional Block Diagram

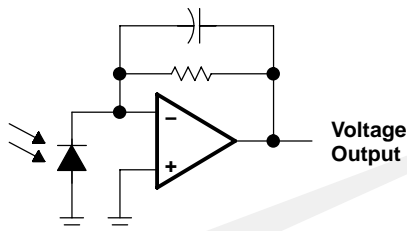

## Available Options

DEVICE	T <sub>A</sub>	PACKAGE – LEADS	PACKAGE DESIGNATOR	ORDERING NUMBER
TSL254R	0°C to 70°C	3-lead Sidelooker	S	TSL254R
TSL254R	0°C to 70°C	3-lead Sidelooker — Lead (Pb) Free	S	TSL254R-LF
TSL254R	0°C to 70°C	3-lead Surface-Mount Sidelooker — Lead (Pb) Free	SM	TSL254RSM-LF

## Terminal Functions

TERMINAL NAME	NO.	DESCRIPTION
GND	1	Ground (substrate). All voltages are referenced to GND.
OUT	3	Output voltage
V <sub>DD</sub>	2	Supply voltage

# TSL254R LIGHT-TO-VOLTAGE OPTICAL SENSOR

TAOS071A – NOVEMBER 2005

## Absolute Maximum Ratings over operating free-air temperature range (unless otherwise noted)†

Supply voltage, $V_{DD}$ (see Note 1)	6 V
Output current, $I_O$	$\pm 10$ mA
Duration of short-circuit current at (or below) 25°C (see Note 2)	5 s
Operating free-air temperature range, $T_A$	-25°C to 85°C
Storage temperature range, $T_{stg}$	-25°C to 85°C
Lead temperature 1,6 mm (1/16 inch) from case for 10 seconds	260°C

† Stresses beyond those listed under “absolute maximum ratings” may cause permanent damage to the device. These are stress ratings only, and functional operation of the device at these or any other conditions beyond those indicated under “recommended operating conditions” is not implied. Exposure to absolute-maximum-rated conditions for extended periods may affect device reliability.

- NOTES: 1. All voltages are with respect to GND.  
2. Output may be shorted to supply.

## Recommended Operating Conditions

	MIN	NOM	MAX	UNIT
Supply voltage, $V_{DD}$	2.7		5.5	V
Operating free-air temperature, $T_A$	0		70	°C

## Electrical Characteristics at $V_{DD} = 5$ V, $T_A = 25^\circ\text{C}$ , $\lambda_p = 635$ nm, $R_L = 10$ k $\Omega$ (unless otherwise noted) (see Notes 3, 4, and 5)

PARAMETER	TEST CONDITIONS	TSL254R			UNIT
		MIN	TYP	MAX	
$V_D$ Dark voltage	$E_e = 0$	0	5	10	mV
$V_{OM}$ Maximum output voltage	$V_{DD} = 4.5$ V	3.0	3.3		V
$V_O$ Output voltage	$E_e = 222 \mu\text{W}/\text{cm}^2$	1.5	2	2.5	V
$\alpha_{vO}$ Temperature coefficient of output voltage ( $V_O$ )	$V_O = 2$ V @ 25°C, $T_A = 0^\circ\text{C}$ to 70°C (see Note 6)	2			mV/°C
		0.1			%/°C
$R_e$ Irradiance responsivity	See Notes 5 and 7	9			mV/(\(\mu\text{W}/\text{cm}^2\))
$I_{DD}$ Supply current	$E_e = 222 \mu\text{W}/\text{cm}^2$	1.1	1.7		mA

- NOTES: 3. Measurements are made with  $R_L = 10$  k $\Omega$  between output and ground.  
4. Optical measurements are made using small-angle incident radiation from an LED optical source.  
5. The input irradiance  $E_e$  is supplied by an AlInGaP LED with peak wavelength  $\lambda_p = 635$  nm  
6. The temperature coefficient of output voltage measurement is made by adjusting irradiance such that  $V_O$  is approximately 2 V at 25°C and then with irradiance held constant, measuring  $V_O$  while varying the temperature between 0°C and 70°C.  
7. Irradiance responsivity is characterized over the range  $V_O = 0.05$  to 2.9 V. The best-fit straight line of Output Voltage  $V_O$  versus irradiance  $E_e$  over this range will typically have a positive extrapolated  $V_O$  value for  $E_e = 0$ .

## Dynamic Characteristics at $V_{DD} = 5$ V, $T_A = 25^\circ\text{C}$ , $\lambda_p = 635$ nm, $R_L = 10$ k $\Omega$ (see Figure 1)

PARAMETER	TEST CONDITIONS	TSL254R			UNIT
		MIN	TYP	MAX	
$t_r$ Output pulse rise time	$V_{O(\text{peak})} = 2$ V	2.5			$\mu\text{s}$
$t_f$ Output pulse fall time	$V_{O(\text{peak})} = 2$ V	2.5			$\mu\text{s}$
$V_n$ Output noise voltage	$E_e = 0$ , $V_O = V_D$ $f = 1$ kHz	1			$\mu\text{V}/\sqrt{\text{Hz}}$
	$E_e = 0$ , $V_O = V_D$ $f = 10$ kHz	1			
	$V_O = 2$ V $f = 1$ kHz	1.5			
	$V_O = 2$ V $f = 10$ kHz	1.5			

PARAMETER MEASUREMENT INFORMATION

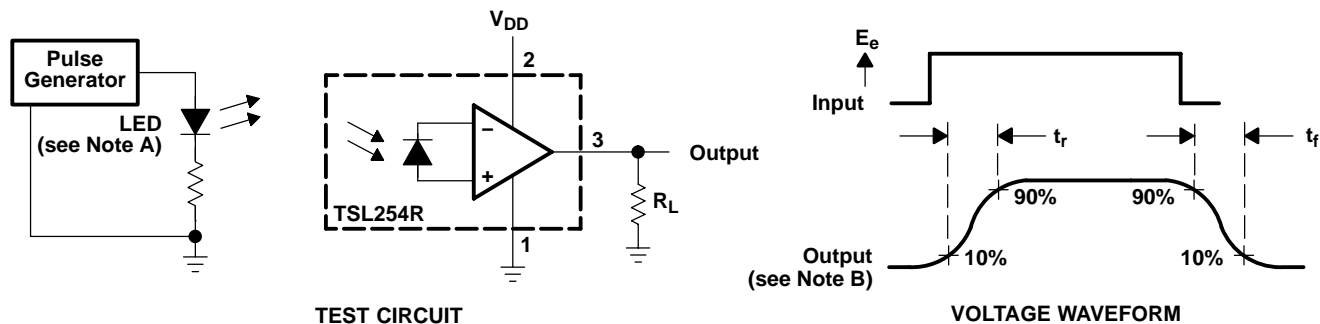

- NOTES: A. The input irradiance is supplied by a pulsed AlInGaP light-emitting diode with the following characteristics:  $\lambda_p = 635 \text{ nm}$ ,  $t_r < 1 \mu\text{s}$ ,  $t_f < 1 \mu\text{s}$ .  
 B. The output waveform is monitored on an oscilloscope with the following characteristics:  $t_r < 100 \text{ ns}$ ,  $Z_i \geq 1 \text{ M}\Omega$ ,  $C_i \leq 20 \text{ pF}$ .

Figure 1. Switching Times

# TSL254R LIGHT-TO-VOLTAGE OPTICAL SENSOR

TAOS071A – NOVEMBER 2005

## TYPICAL CHARACTERISTICS

OUTPUT VOLTAGE  
vs  
IRRADIANCE

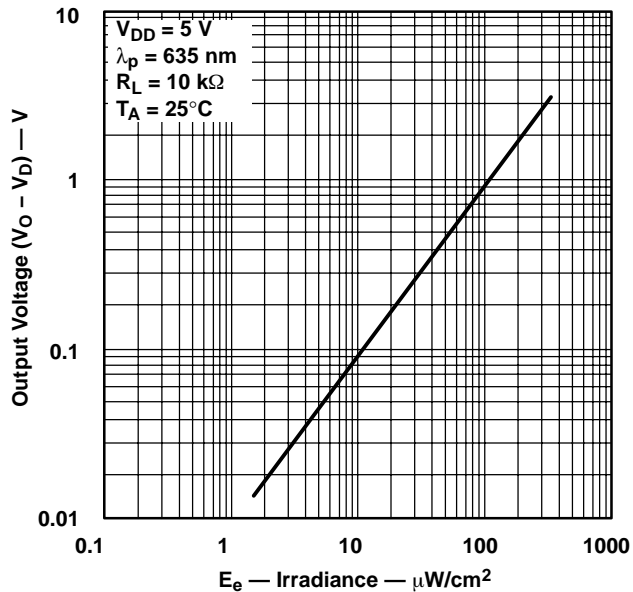

Figure 2

PHOTODIODE SPECTRAL RESPONSIVITY

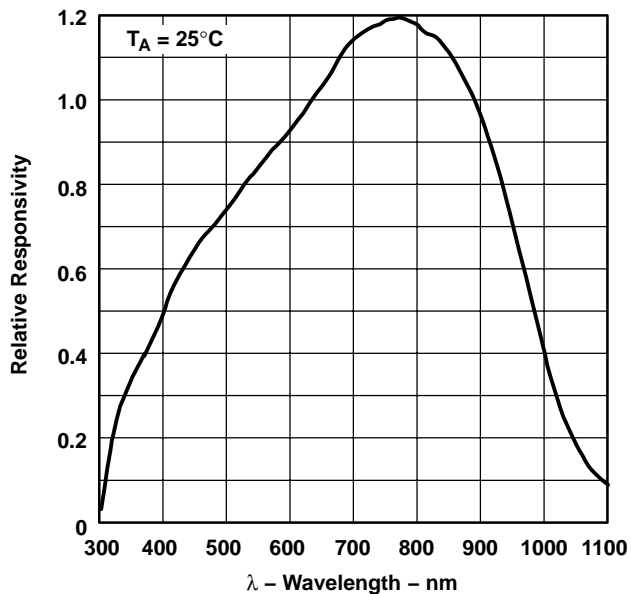

Figure 3

MAXIMUM OUTPUT VOLTAGE  
vs  
SUPPLY VOLTAGE

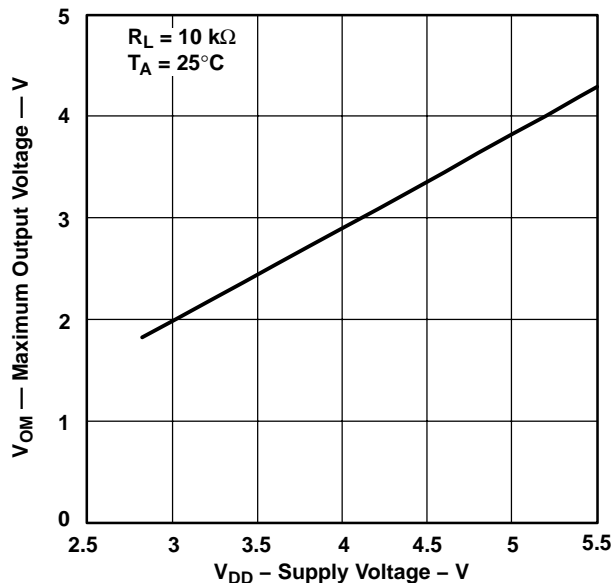

Figure 4

SUPPLY CURRENT  
vs  
OUTPUT VOLTAGE

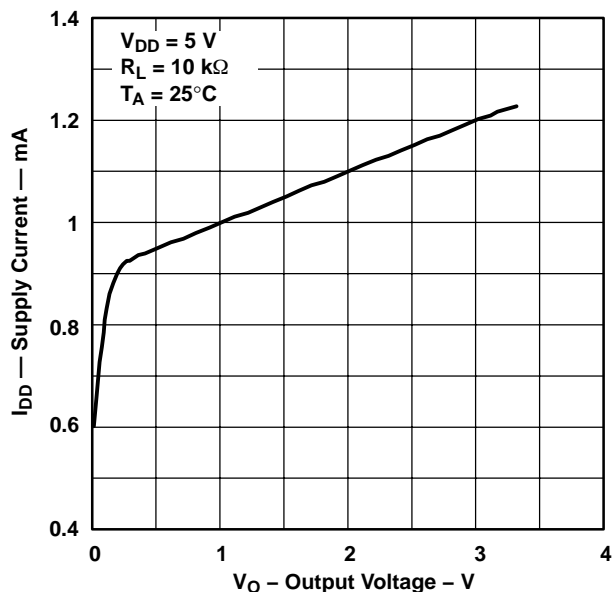

Figure 5

TYPICAL CHARACTERISTICS

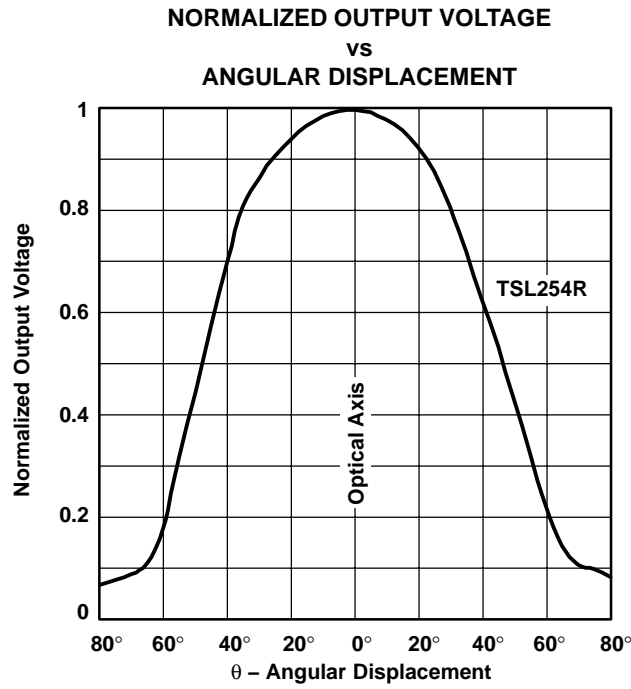

Figure 6

# TSL254R LIGHT-TO-VOLTAGE OPTICAL SENSOR

TAOS071A – NOVEMBER 2005

## MECHANICAL INFORMATION

The device is supplied in a clear plastic three-lead package (S). The integrated photodiode active area is typically 1,0 mm<sup>2</sup> (0.0016 in<sup>2</sup>).

### PACKAGE S

### PLASTIC SINGLE-IN-LINE SIDE-LOOKER PACKAGE

#### TOP VIEW

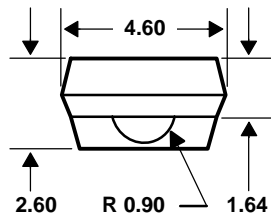

#### FRONT VIEW

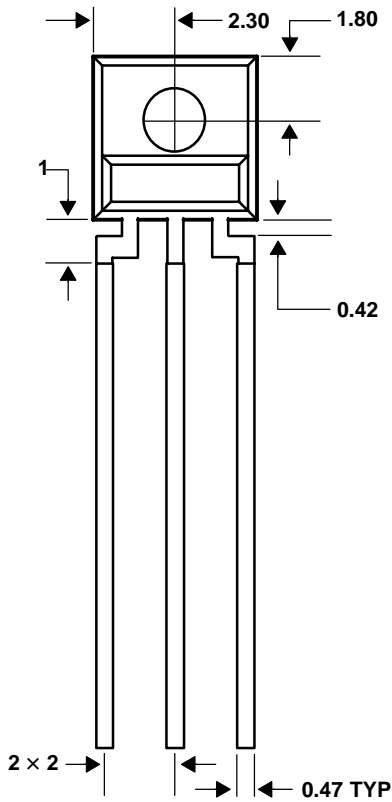

#### SIDE VIEW

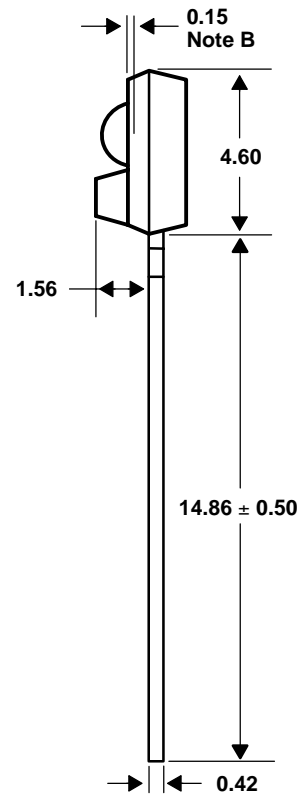

Lead Free Available

- NOTES: A. All linear dimensions are in millimeters; tolerance is  $\pm 0.25$  mm unless otherwise stated.  
 B. Dimension is to center of lens arc, which is located below the package face.  
 C. The integrated photodiode active area is typically located in the center of the lens and 0.97 mm below the top of the lens surface.  
 D. Index of refraction of clear plastic is 1.55.  
 E. Lead finish for TSL254R solder dipped, 63% Sn/37% Pb. Lead finish for TSL254R-LF: solder dipped, 100% Sn.  
 F. This drawing is subject to change without notice.

Figure 7. Package S — Single-In-Line Side-Looker Package Configuration

MECHANICAL DATA

PACKAGE SM

PLASTIC SURFACE MOUNT SIDE-LOOKER PACKAGE

TOP VIEW

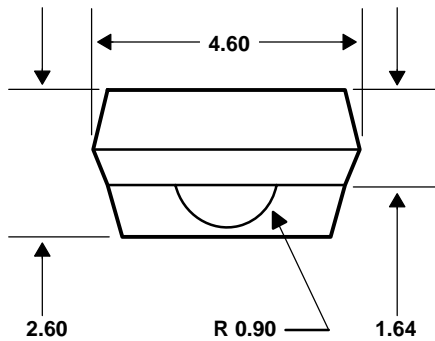

FRONT VIEW

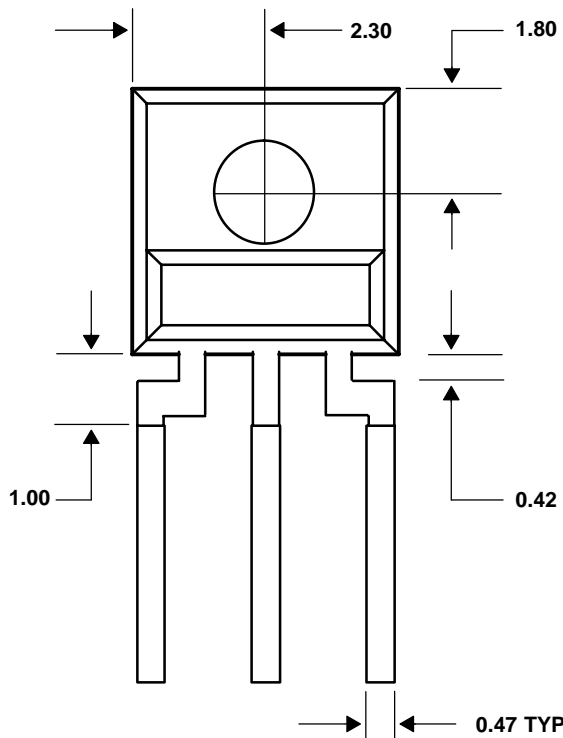

SIDE VIEW

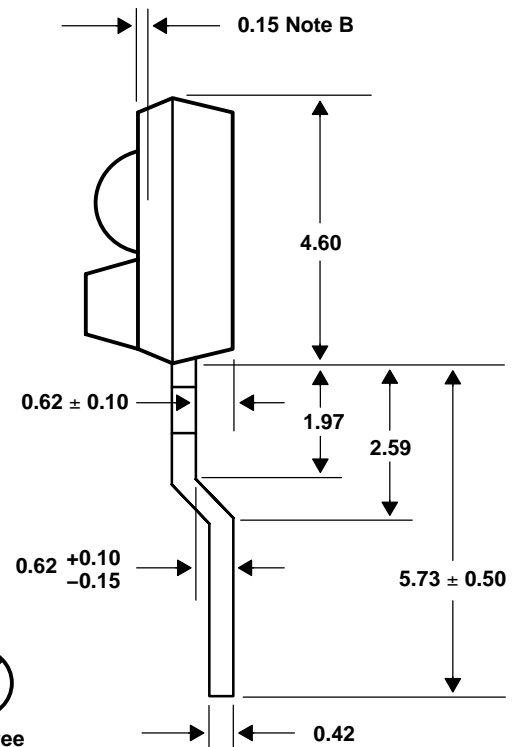

- NOTES: A. All linear dimensions are in millimeters; tolerance is  $\pm 0.25$  mm unless otherwise stated.  
 B. Dimension is to center of lens arc, which is located below the package face.  
 C. The integrated photodiode active area is typically located in the center of the lens and 0.97 mm below the top of the lens surface.  
 D. Index of refraction of clear plastic is 1.55.  
 E. Lead finish for TSL254RSM-LF: solder dipped, 100% Sn.  
 F. This drawing is subject to change without notice.

Figure 8. Package SM — Surface Mount Side-Looker Package Configuration

# TSL254R LIGHT-TO-VOLTAGE OPTICAL SENSOR

TAOS071A – NOVEMBER 2005

---

**PRODUCTION DATA** — information in this document is current at publication date. Products conform to specifications in accordance with the terms of Texas Advanced Optoelectronic Solutions, Inc. standard warranty. Production processing does not necessarily include testing of all parameters.

## ***LEAD-FREE (Pb-FREE) and GREEN STATEMENT***

**Pb-Free (RoHS)** TAOS' terms *Lead-Free* or *Pb-Free* mean semiconductor products that are compatible with the current RoHS requirements for all 6 substances, including the requirement that lead not exceed 0.1% by weight in homogeneous materials. Where designed to be soldered at high temperatures, TAOS Pb-Free products are suitable for use in specified lead-free processes.

**Green (RoHS & no Sb/Br)** TAOS defines *Green* to mean Pb-Free (RoHS compatible), and free of Bromine (Br) and Antimony (Sb) based flame retardants (Br or Sb do not exceed 0.1% by weight in homogeneous material).

**Important Information and Disclaimer** The information provided in this statement represents TAOS' knowledge and belief as of the date that it is provided. TAOS bases its knowledge and belief on information provided by third parties, and makes no representation or warranty as to the accuracy of such information. Efforts are underway to better integrate information from third parties. TAOS has taken and continues to take reasonable steps to provide representative and accurate information but may not have conducted destructive testing or chemical analysis on incoming materials and chemicals. TAOS and TAOS suppliers consider certain information to be proprietary, and thus CAS numbers and other limited information may not be available for release.

## ***NOTICE***

Texas Advanced Optoelectronic Solutions, Inc. (TAOS) reserves the right to make changes to the products contained in this document to improve performance or for any other purpose, or to discontinue them without notice. Customers are advised to contact TAOS to obtain the latest product information before placing orders or designing TAOS products into systems.

TAOS assumes no responsibility for the use of any products or circuits described in this document or customer product design, conveys no license, either expressed or implied, under any patent or other right, and makes no representation that the circuits are free of patent infringement. TAOS further makes no claim as to the suitability of its products for any particular purpose, nor does TAOS assume any liability arising out of the use of any product or circuit, and specifically disclaims any and all liability, including without limitation consequential or incidental damages.

TEXAS ADVANCED OPTOELECTRONIC SOLUTIONS, INC. PRODUCTS ARE NOT DESIGNED OR INTENDED FOR USE IN CRITICAL APPLICATIONS IN WHICH THE FAILURE OR MALFUNCTION OF THE TAOS PRODUCT MAY RESULT IN PERSONAL INJURY OR DEATH. USE OF TAOS PRODUCTS IN LIFE SUPPORT SYSTEMS IS EXPRESSLY UNAUTHORIZED AND ANY SUCH USE BY A CUSTOMER IS COMPLETELY AT THE CUSTOMER'S RISK.

LUMENOLOGY, TAOS, the TAOS logo, and Texas Advanced Optoelectronic Solutions are registered trademarks of Texas Advanced Optoelectronic Solutions Incorporated.