

- Monolithic Silicon IC Containing Photodiode, Operational Amplifier, and Feedback Components
- Converts Light Intensity to a Voltage
- High Irradiance Responsivity, Typically 137 mV/( $\mu\text{W}/\text{cm}^2$ ) at  $\lambda_p = 635 \text{ nm}$  (TSL250R)
- Compact 3-Lead Clear Plastic Package
- Single Voltage Supply Operation
- Low Dark (Offset) Voltage....10 mV Max
- Low Supply Current.....1.1 mA Typical
- Wide Supply-Voltage Range.... 2.7 V to 5.5 V
- Replacements for TSL250, TSL251, and TSL252
- RoHS Compliant (–LF Package Only)

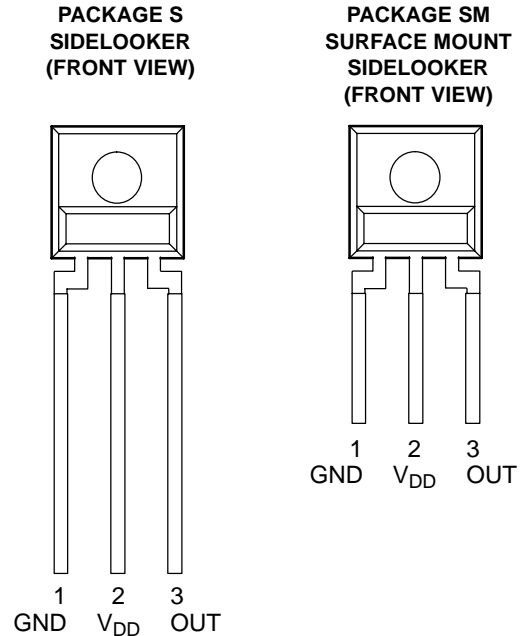

## Description

The TSL250R, TSL251R, and TSL252R are light-to-voltage optical sensors, each combining a photodiode and a transimpedance amplifier (feedback resistor = 16 M $\Omega$ , 8 M $\Omega$ , and 2.8 M $\Omega$  respectively) on a single monolithic IC. Output voltage is directly proportional to the light intensity (irradiance) on the photodiode. These devices have improved amplifier offset-voltage stability and low power consumption and are supplied in a 3-lead clear plastic sidelooker package with an integral lens. When supplied in the lead (Pb) free package, the device is RoHS compliant.

## Functional Block Diagram

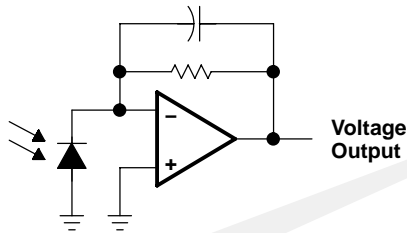

## Available Options

DEVICE	T <sub>A</sub>	PACKAGE – LEADS	PACKAGE DESIGNATOR	ORDERING NUMBER
TSL250R	0°C to 70°C	3-lead Sidelooker	S	TSL250R
TSL250R	0°C to 70°C	3-lead Sidelooker — Lead (Pb) Free	S	TSL250R–LF
TSL250R	0°C to 70°C	3-lead Surface-Mount Sidelooker — Lead (Pb) Free	SM	TSL250RSM–LF
TSL251R	0°C to 70°C	3-lead Sidelooker	S	TSL251R
TSL251R	0°C to 70°C	3-lead Sidelooker — Lead (Pb) Free	S	TSL251R–LF
TSL251R	0°C to 70°C	3-lead Surface-Mount Sidelooker — Lead (Pb) Free	SM	TSL251RSM–LF
TSL252R	0°C to 70°C	3-lead Sidelooker	S	TSL252R
TSL252R	0°C to 70°C	3-lead Sidelooker — Lead (Pb) Free	S	TSL252R–LF
TSL252R	0°C to 70°C	3-lead Surface-Mount Sidelooker — Lead (Pb) Free	SM	TSL252RSM–LF

# TSL250R, TSL251R, TSL252R LIGHT-TO-VOLTAGE OPTICAL SENSORS

TAOS028F – NOVEMBER 2005

## Terminal Functions

TERMINAL NAME	NO.	DESCRIPTION
GND	1	Ground (substrate). All voltages are referenced to GND.
OUT	3	Output voltage
V <sub>DD</sub>	2	Supply voltage

## Absolute Maximum Ratings over operating free-air temperature range (unless otherwise noted)<sup>†</sup>

Supply voltage, V <sub>DD</sub> (see Note 1)	6 V
Output current, I <sub>O</sub>	±10 mA
Duration of short-circuit current at (or below) 25°C (see Note 2)	5 s
Operating free-air temperature range, T <sub>A</sub>	–25°C to 85°C
Storage temperature range, T <sub>stg</sub>	–25°C to 85°C
Lead temperature 1,6 mm (1/16 inch) from case for 10 seconds	260°C

<sup>†</sup> Stresses beyond those listed under “absolute maximum ratings” may cause permanent damage to the device. These are stress ratings only, and functional operation of the device at these or any other conditions beyond those indicated under “recommended operating conditions” is not implied. Exposure to absolute-maximum-rated conditions for extended periods may affect device reliability.

NOTES: 1. All voltages are with respect to GND.  
2. Output may be shorted to supply.

## Recommended Operating Conditions

	MIN	NOM	MAX	UNIT
Supply voltage, V <sub>DD</sub>	2.7		5.5	V
Operating free-air temperature, T <sub>A</sub>	0		70	°C

Electrical Characteristics at  $V_{DD} = 5\text{ V}$ ,  $T_A = 25^\circ\text{C}$ ,  $\lambda_p = 635\text{ nm}$ ,  $R_L = 10\text{ k}\Omega$  (unless otherwise noted) (see Notes 3, 4, and 5)

PARAMETER	TEST CONDITIONS	TSL250R			TSL251R			TSL252R			UNIT
		MIN	TYP	MAX	MIN	TYP	MAX	MIN	TYP	MAX	
$V_D$ Dark voltage	$E_e = 0$	0	4	10	0	4	10	0	4	10	mV
$V_{OM}$ Maximum output voltage	$V_{DD} = 4.5\text{ V}$	3.0	3.3		3.0	3.3		3.0	3.3		V
$V_O$ Output voltage	$E_e = 14.6\ \mu\text{W}/\text{cm}^2$	1.5	2	2.5							V
	$E_e = 38.5\ \mu\text{W}/\text{cm}^2$				1.5	2	2.5				
	$E_e = 196\ \mu\text{W}/\text{cm}^2$							1.5	2	2.5	
$\alpha_{vo}$ Temperature coefficient of output voltage ( $V_O$ )	$E_e = 14.6\ \mu\text{W}/\text{cm}^2$ , $T_A = 0^\circ\text{C}$ to $70^\circ\text{C}$	1.6									mV/ $^\circ\text{C}$
		0.08									%/ $^\circ\text{C}$
	$E_e = 38.5\ \mu\text{W}/\text{cm}^2$ , $T_A = 0^\circ\text{C}$ to $70^\circ\text{C}$				1.6						mV/ $^\circ\text{C}$
					0.08						%/ $^\circ\text{C}$
$N_e$ Irradiance responsivity	$\lambda_p = 635\text{ nm}$ , See Notes 5 and 7	137			52			10.2			mV/ $(\mu\text{W}/\text{cm}^2)$
	$\lambda_p = 880\text{ nm}$ , See Notes 6 and 7	127			48			9.4			
$I_{DD}$ Supply current	$E_e = 14.6\ \mu\text{W}/\text{cm}^2$	1.1			1.7						mA
	$E_e = 38.5\ \mu\text{W}/\text{cm}^2$				1.1			1.7			
	$E_e = 196\ \mu\text{W}/\text{cm}^2$							1.1			

- NOTES: 3. Measurements are made with  $R_L = 10\text{ k}\Omega$  between output and ground.  
 4. Optical measurements are made using small-angle incident radiation from an LED optical source.  
 5. The input irradiance  $E_e$  is supplied by an AlInGaP LED with peak wavelength  $\lambda_p = 635\text{ nm}$   
 6. The input irradiance  $E_e$  is supplied by a GaAlAs LED with peak wavelength  $\lambda_p = 880\text{ nm}$   
 7. Irradiance responsivity is characterized over the range  $V_O = 0.05$  to  $2.9\text{ V}$ . The best-fit straight line of Output Voltage  $V_O$  versus irradiance  $E_e$  over this range will typically have a positive extrapolated  $V_O$  value for  $E_e = 0$ .

Dynamic Characteristics at  $T_A = 25^\circ\text{C}$  (see Figure 1)

PARAMETER	TEST CONDITIONS	TSL250R			TSL251R			TSL252R			UNIT
		MIN	TYP	MAX	MIN	TYP	MAX	MIN	TYP	MAX	
$t_r$ Output pulse rise time	$V_{DD} = 5\text{ V}$ , $\lambda_p = 635\text{ nm}$	260			70			7			$\mu\text{s}$
$t_f$ Output pulse fall time	$V_{DD} = 5\text{ V}$ , $\lambda_p = 635\text{ nm}$	260			70			7			$\mu\text{s}$
$V_n$ Output noise voltage	$V_{DD} = 5\text{ V}$ , $E_e = 0$ , $f = 1000\text{ Hz}$	0.8			0.7			0.6			$\mu\text{V}/\sqrt{\text{Hz}}$

# TSL250R, TSL251R, TSL252R LIGHT-TO-VOLTAGE OPTICAL SENSORS

TAOS028F – NOVEMBER 2005

## PARAMETER MEASUREMENT INFORMATION

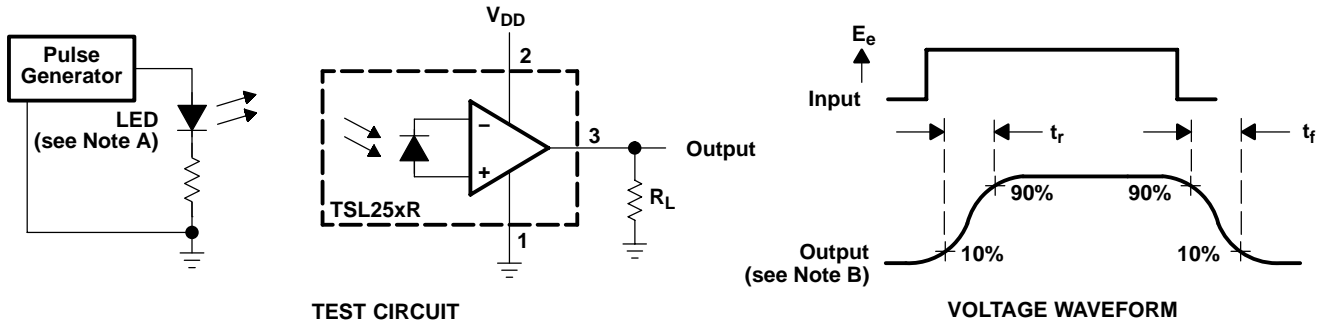

- NOTES: A. The input irradiance is supplied by a pulsed AlInGaP light-emitting diode with the following characteristics:  $\lambda_p = 635 \text{ nm}$ ,  $t_r < 1 \mu\text{s}$ ,  $t_f < 1 \mu\text{s}$ .
- B. The output waveform is monitored on an oscilloscope with the following characteristics:  $t_r < 100 \text{ ns}$ ,  $Z_i \geq 1 \text{ M}\Omega$ ,  $C_i \leq 20 \text{ pF}$ .

Figure 1. Switching Times

## TYPICAL CHARACTERISTICS

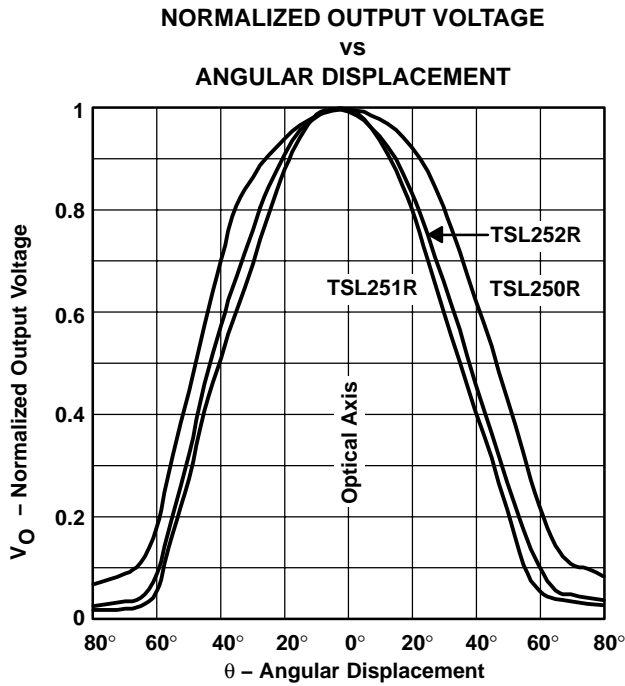
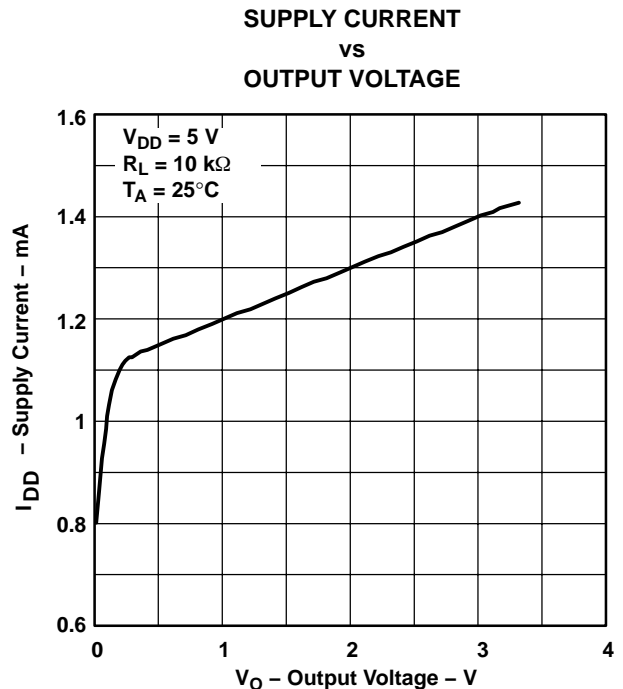
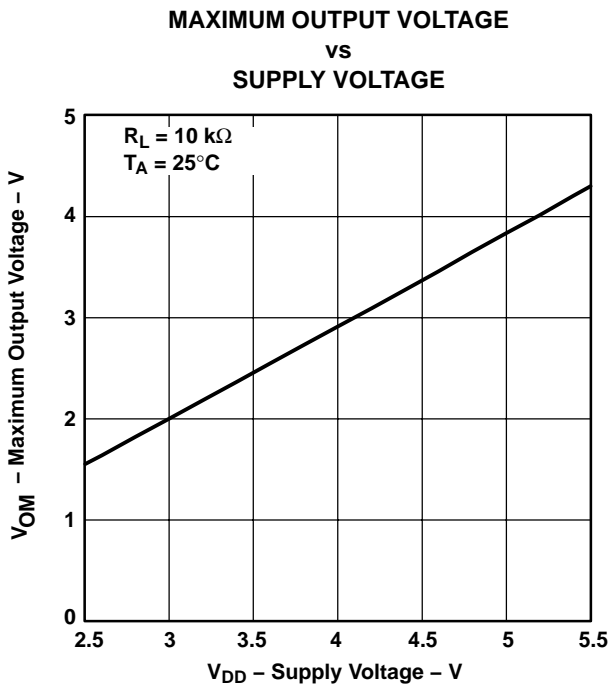
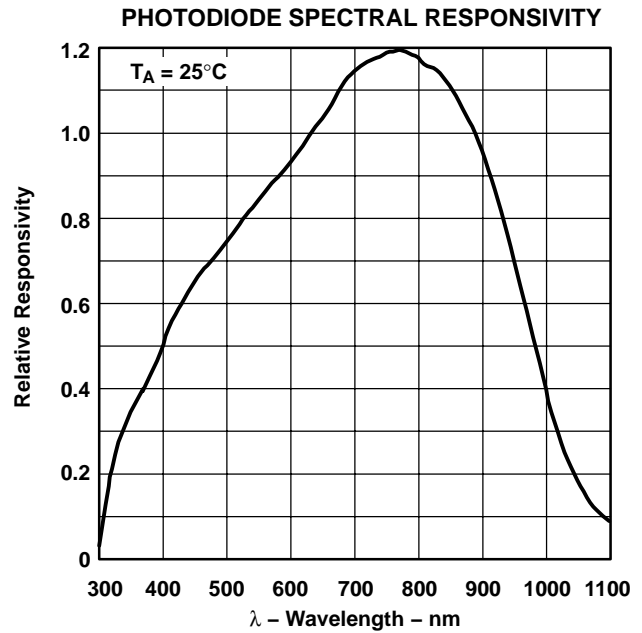
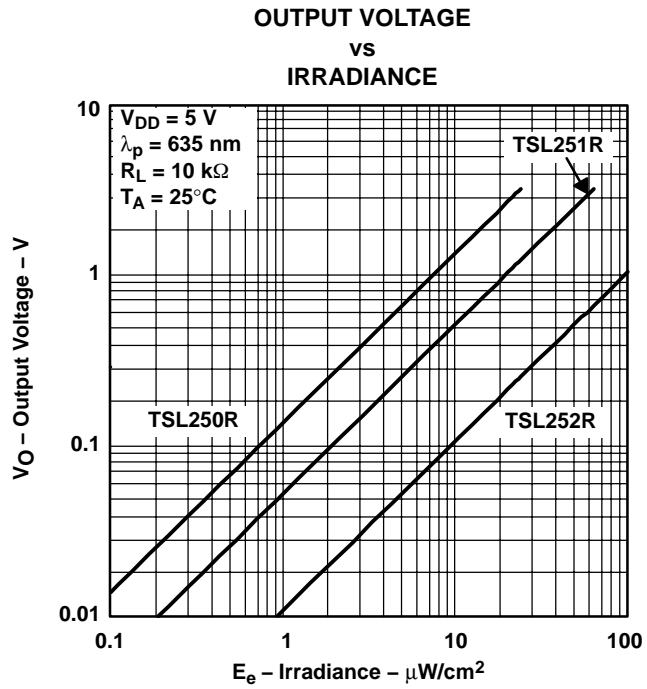

Figure 2

TYPICAL CHARACTERISTICS



# TSL250R, TSL251R, TSL252R LIGHT-TO-VOLTAGE OPTICAL SENSORS

TAOS028F – NOVEMBER 2005

## MECHANICAL INFORMATION

The devices are supplied in a clear plastic three-lead package (S). The integrated photodiode active area is typically 1,0 mm<sup>2</sup> (0.0016 in<sup>2</sup>) for TSL250R, 0,5 mm<sup>2</sup> (0.00078 in<sup>2</sup>) for the TSL251R, and 0,26 mm<sup>2</sup> (0.0004 in<sup>2</sup>) for the TSL252R.

### PACKAGE S

### PLASTIC SINGLE-IN-LINE SIDE-LOOKER PACKAGE

#### TOP VIEW

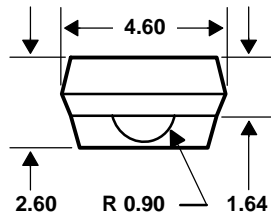

#### FRONT VIEW

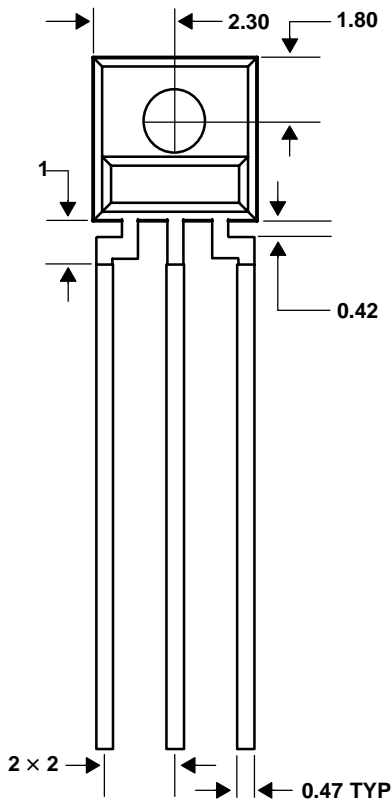

#### SIDE VIEW

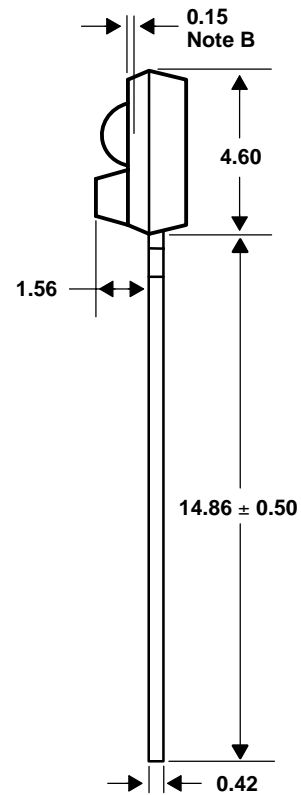

Lead Free  
Available

- NOTES: A. All linear dimensions are in millimeters; tolerance is  $\pm 0.25$  mm unless otherwise stated.  
 B. Dimension is to center of lens arc, which is located below the package face.  
 C. The integrated photodiode active area is typically located in the center of the lens and 0.97 mm below the top of the lens surface.  
 D. Index of refraction of clear plastic is 1.55.  
 E. Lead finish for TSL25xR: solder dipped, 63% Sn/37% Pb. Lead finish for TSL25xR-LF: solder dipped, 100% Sn.  
 F. This drawing is subject to change without notice.

Figure 7. Package Configuration

MECHANICAL DATA

PACKAGE SM

PLASTIC SURFACE MOUNT SIDE-LOOKER PACKAGE

TOP VIEW

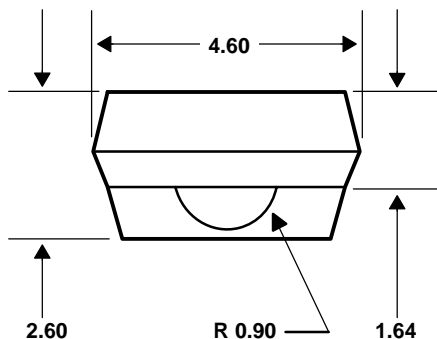

FRONT VIEW

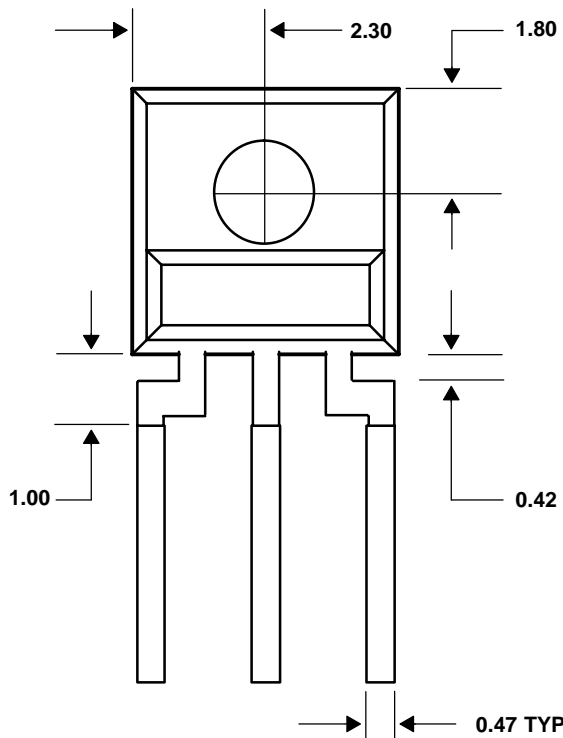

SIDE VIEW

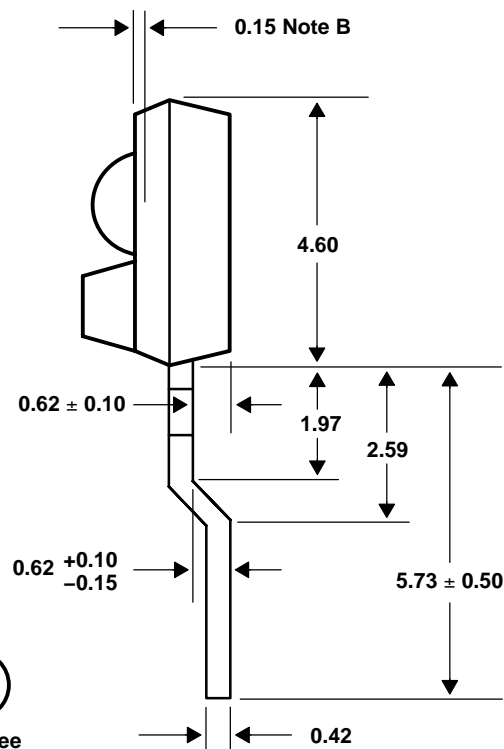

- NOTES: A. All linear dimensions are in millimeters; tolerance is  $\pm 0.25$  mm unless otherwise stated.  
 B. Dimension is to center of lens arc, which is located below the package face.  
 C. The integrated photodiode active area is typically located in the center of the lens and 0.97 mm below the top of the lens surface.  
 D. Index of refraction of clear plastic is 1.55.  
 E. Lead finish for TSL25xRSM-LF: solder dipped, 100% Sn.  
 F. This drawing is subject to change without notice.

Figure 8. Package SM — Surface Mount Side-Looker Package Configuration

# TSL250R, TSL251R, TSL252R LIGHT-TO-VOLTAGE OPTICAL SENSORS

TAOS028F – NOVEMBER 2005

---

**PRODUCTION DATA** — information in this document is current at publication date. Products conform to specifications in accordance with the terms of Texas Advanced Optoelectronic Solutions, Inc. standard warranty. Production processing does not necessarily include testing of all parameters.

## ***LEAD-FREE (Pb-FREE) and GREEN STATEMENT***

**Pb-Free (RoHS)** TAOS' terms *Lead-Free* or *Pb-Free* mean semiconductor products that are compatible with the current RoHS requirements for all 6 substances, including the requirement that lead not exceed 0.1% by weight in homogeneous materials. Where designed to be soldered at high temperatures, TAOS Pb-Free products are suitable for use in specified lead-free processes.

**Green (RoHS & no Sb/Br)** TAOS defines *Green* to mean Pb-Free (RoHS compatible), and free of Bromine (Br) and Antimony (Sb) based flame retardants (Br or Sb do not exceed 0.1% by weight in homogeneous material).

**Important Information and Disclaimer** The information provided in this statement represents TAOS' knowledge and belief as of the date that it is provided. TAOS bases its knowledge and belief on information provided by third parties, and makes no representation or warranty as to the accuracy of such information. Efforts are underway to better integrate information from third parties. TAOS has taken and continues to take reasonable steps to provide representative and accurate information but may not have conducted destructive testing or chemical analysis on incoming materials and chemicals. TAOS and TAOS suppliers consider certain information to be proprietary, and thus CAS numbers and other limited information may not be available for release.

## ***NOTICE***

Texas Advanced Optoelectronic Solutions, Inc. (TAOS) reserves the right to make changes to the products contained in this document to improve performance or for any other purpose, or to discontinue them without notice. Customers are advised to contact TAOS to obtain the latest product information before placing orders or designing TAOS products into systems.

TAOS assumes no responsibility for the use of any products or circuits described in this document or customer product design, conveys no license, either expressed or implied, under any patent or other right, and makes no representation that the circuits are free of patent infringement. TAOS further makes no claim as to the suitability of its products for any particular purpose, nor does TAOS assume any liability arising out of the use of any product or circuit, and specifically disclaims any and all liability, including without limitation consequential or incidental damages.

TEXAS ADVANCED OPTOELECTRONIC SOLUTIONS, INC. PRODUCTS ARE NOT DESIGNED OR INTENDED FOR USE IN CRITICAL APPLICATIONS IN WHICH THE FAILURE OR MALFUNCTION OF THE TAOS PRODUCT MAY RESULT IN PERSONAL INJURY OR DEATH. USE OF TAOS PRODUCTS IN LIFE SUPPORT SYSTEMS IS EXPRESSLY UNAUTHORIZED AND ANY SUCH USE BY A CUSTOMER IS COMPLETELY AT THE CUSTOMER'S RISK.

LUMENOLOGY, TAOS, the TAOS logo, and Texas Advanced Optoelectronic Solutions are registered trademarks of Texas Advanced Optoelectronic Solutions Incorporated.