



SPECIFICATION FOR OLED MODULE TAT07

TABLE OF CONTENTS

- 1. PURPOSE 2**
- 2. PRODUCT SPECIFICATIONS..... 2**
 - 2.1 Module Revision and ordering number 2
 - 2.2 Basic Specification 2
 - 2.3 Mechanical Characteristics 2
 - 2.4 Absolute Maximum Ratings 2
 - 2.5 Electrical Characteristics 3
 - 2.6 LCD Electrical & Optical characteristics 3
 - 2.6.1 Definition of optical characteristics 4
 - 2.6.2 Definition of viewing angle 5
 - 2.6.3 Definition of response time 5
 - 2.7 Mechanical drawing 6
 - 2.7.1 Pin connection (signal function) 7
- 3. QUALIFICATION PROCEDURE 7**
 - 3.1 Tests to be performed on prototypes, preserie 7
 - 3.2 Packing reliability 8
- 4. MARKINGS 8**
- 5. SHIPMENT METHOD 8**
 - 5.1 Internal Packaging 8
- 6. RECEIVING INSPECTION 8**
- 7. QUALITY ASSURANCE 8**
 - 7.1 Conformity 8
 - 7.2 Responsibility 8
 - 7.3 Shipping Inspection Standards 9
 - 7.3.1 Shipping Inspection Standards 9
 - 7.3.2 Zone Definitions 9
 - 7.3.3 Visual Inspection 9
 - 7.3.4 Limit Sample 9
 - 7.3.5 Individual Appearance Defects Standards (Back light ON and OFF / Display OFF) 10
 - 7.3.6 Individual appearance defects standards (display ON) 11
 - 7.3.7 Chipped Glass Defect Standard 12
 - 7.3.8 FPC 13
- 8. OPERATIONS PRECAUTIONS 14**
 - 8.1 Safety 14
 - 8.2 Handling 14
 - 8.3 Mounting and Design 14
 - 8.4 Storage 14
 - 8.5 Cleaning 14
- 9. APPENDIX 1: PLASTIC TRAY DRAWING 15**
- 10. APPENDIX 2: PALLET ASSEMBLY DRAWING 16**
- 11. SPECIFICATION HISTORY 17**
- 12. ATTACHMENTS 17**
- 13. CUSTOMER APPROVAL 17**



1. PURPOSE

This specification covers the delivery requirements for the display module delivered by EM Microelectronic-Marine SA.

2. PRODUCT SPECIFICATIONS

2.1 MODULE REVISION AND ORDERING NUMBER

EM Part Number	Customer Part Number	Remarks
TAT07_R01	TBD	Initial revision

2.2 BASIC SPECIFICATION

ITEM	CHARACTERISTICS
Display technology	OLED monochrome, color yellow
Layout	Dot matrix
LCD Driver	SSD1305Z
Interface	Selectable with BS2 and BS1 signals
LCD Module structure	COG+FPC
Estimated useful life time at ambient conditions	60 khours operating until half brightness 80 khours storage

2.3 MECHANICAL CHARACTERISTICS

ITEM	CHARACTERISTICS
Dots configuration	128 x 64
Dots dimensions (mm)	0.254 (L) x 0.254 (W)
Dots gap (mm)	0.020
Module size (L x W x T, mm)	40.3 (L) x 63.3 (W) x 2.01 (T)
Panel size	40.3 (L) x 27.3 (W) x2.01 (T)
Diagonal AA size	1.54"
Weight (g)	TBD

2.4 ABSOLUTE MAXIMUM RATINGS

Vss = 0 V, Ambient Temp.= 25 °C

Item	Symbol	Condition	Min	Max	Unit
Power supply voltage	Vdd	25 °C	-0.3	+3.5	V
Supply voltage	Vcc	25 °C	8	16	V
Operating temperature	Topr	---	0	+50	°C
Storage temperature	Tstg	---	-20	+70	°C
Operating & storage humidity	RHoprstg	---	0	85	%RH



2.5 ELECTRICAL CHARACTERISTICS

V_{SS} = 0 V, Ambient Temp. = 25 °C

Item	Symbol	Condition	Min	Typ	Max	Unit
Power supply voltage	V _{DD}	25 °C	2.4	3.0	3.5	V
OLED operating voltage	V _{CC}	25 °C	-	12.5	-	V
Current consumption	I _{DD}	25 °C V _{DD} = Typ. V _{CC} = Typ.	-	130	tbd	μA
	I _{CC}	Contrast setting = 0xFF 100% Display ON	-	10.5	tbd	mA

2.6 LCD ELECTRICAL & OPTICAL CHARACTERISTICS

ITEM	SYMBOL	CONDITIONS	TEMP	MIN	TYP	MAX	UNIT
Contrast Ratio	*CR	Driving conditions	25°C		500	-	-
Brightness	B	Driving conditions	25°C		100		cd/m ²
Viewing angle	θ, X axis	Driving conditions CR > 2	25°C	-80	-	+80	deg.
	θ, Y axis			-80	-	+80	
Response time	ton	Driving conditions	25°C		10		μs
		Driving conditions	0°C		-	-	
		Driving conditions					
	toff	Driving conditions	25°C		10		
		Driving conditions	0°C		-	-	

2.6.1 Definition of optical characteristics

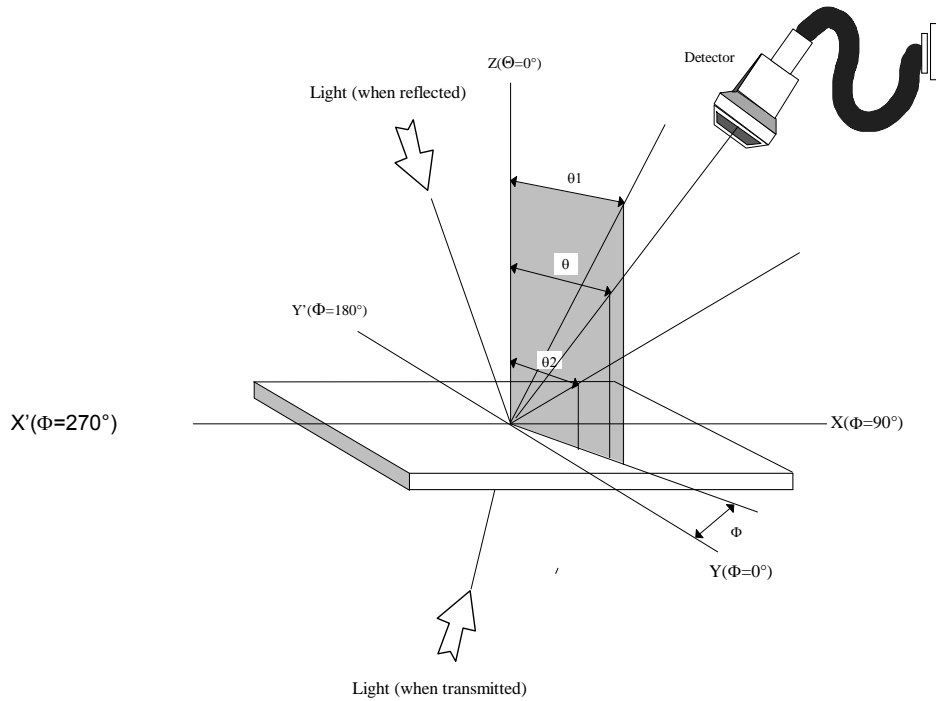

Definition of contrast Cr.
$$Cr. = \frac{B2}{B1} = \frac{\text{Brightness of selected segment}}{\text{Brightness of not selected segment}}$$

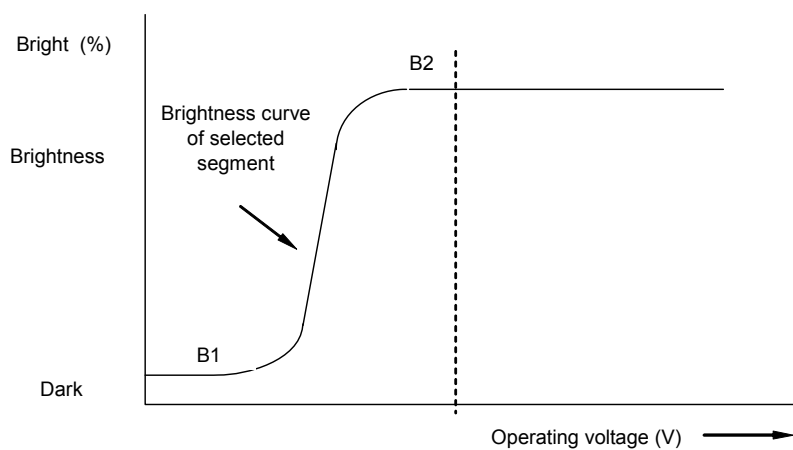

2.6.2 Definition of viewing angle

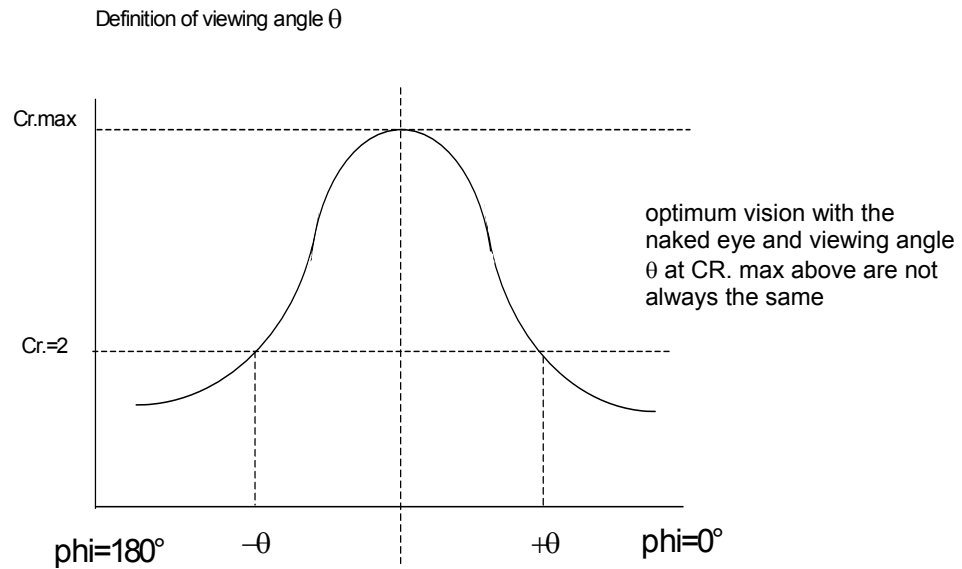

2.6.3 Definition of response time

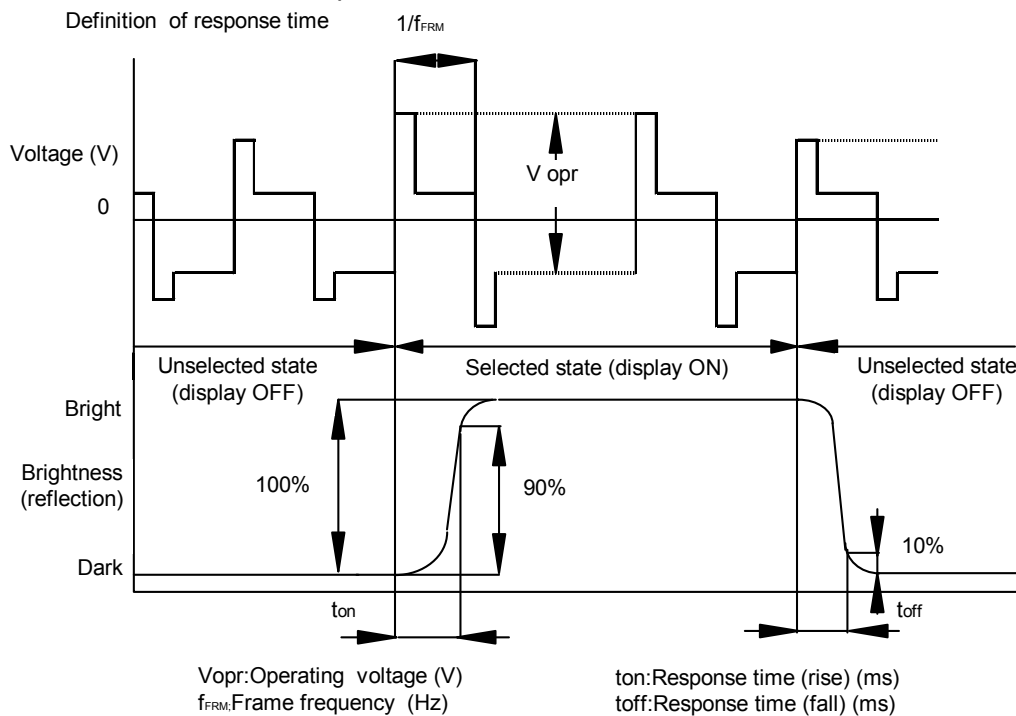

2.7 MECHANICAL DRAWING

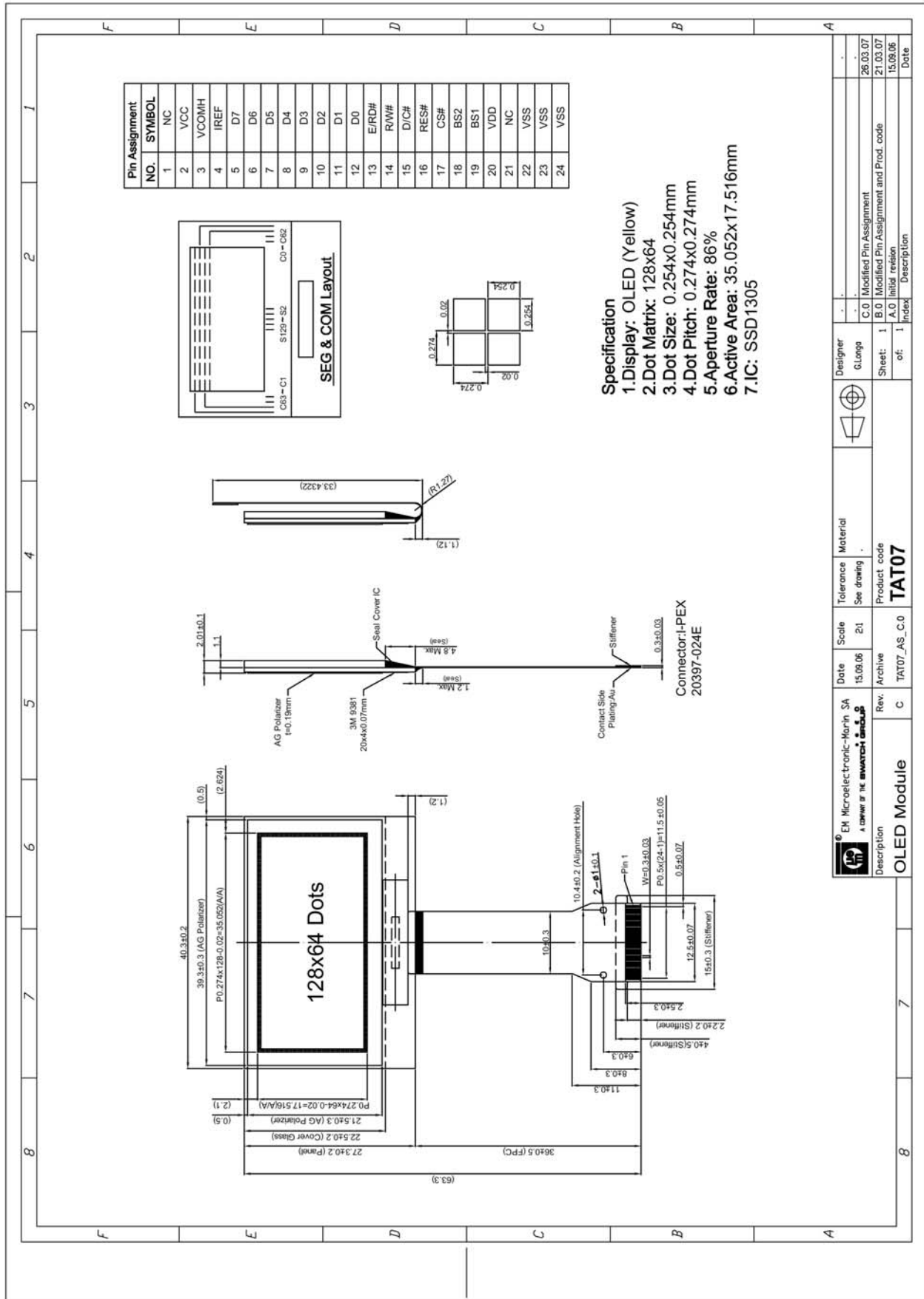

Designer	G.Longo
Date	15.09.06
Scale	2:1
Tolerance	See drawing
Material	
Product code	TAT07
Rev.	C
Archive	TAT07_AS_C.0
Description	OLED Module

EM Microelectronic-Marin SA	26.03.07
A COMPANY OF THE SWATCH GROUP	21.03.07
C.O Modified Pin Assignment	15.09.06
B.O Modified Pin Assignment and Prod. code	
A.O Initial revision	
of: 1	
Index	
Description	
Date	



2.7.1 Pin connection (signal function)

See mechanical drawing

3. QUALIFICATION PROCEDURE

3.1 TESTS TO BE PERFORMED ON PROTOTYPES, PRESERIE

Test ref.	Test name	Test conditions	Test condition	Criteria	Proto- types (pcs)	Preserie (pcs)
MC	Mechanical characterization	Complete critical mechanical dimension report (once for all with first article inspection report and each time major modification is done).	25°C	0 defects	10	30
EC	Electrical characterization	Idd, Vcc (once for all with first article inspection report and each time major modification is done).	25°C	0 defects	10	30
OC	Optical characterization	Brightness, contrast (once for all with first article inspection report and each time major modification is done)	25°C	0 defects	2	2
VT	Visual test in all operating temperature ranges	Display to be controlled visually for brightness over all operating temperature ranges.	Operating temperature range Driving mode	Readable, over operating temperature, 0 defects	2	2
TST	Thermal shock test	-20°C to 70°C, 5 cycles , 2h/2h, transfer time 1min @ 25°C	Non driving mode	Functional, brightness ≥ 50% of initial value, current consumption < 2x initial value, 0 defects	10	10
AHTO	Accelerated humidity test operating	40°C / 85% RH 240 hours	Driving mode	Functional, brightness ≥ 50% of initial value, current consumption < 2x initial value, 0 defects	10	10
RV	Vibration test	Frequency range: 5-500 Hz 5Hz: 0.10 (m/s ²) 2/Hz 12Hz: 2.20 (m/s ²) 2/Hz 20Hz: 2.20 (m/s ²) 2/Hz 200Hz: 0.04 (m/s ²) 2/Hz 500Hz: 0.04 (m/s ²) 2/Hz Duration 2 hours in each direction (X, Y, Z) Operating mode: ON	25°C (test will be performed by customer)	Functional, 0 defects	5	5
DH	Dry heat	70°C / 16h	Intermittent driving	Hot start, functional, readable	5	5
C	Cold	-20°C / 16h	Intermittent driving	Cold start (no condensation), functional, readable	5	5



3.2 PACKING RELIABILITY

The internal and external packaging has to be released and qualified by following tests:

Condition	Test	Acceptable results
Take one external box filled with the required inner boxes completed with LCD products	Drop the external box from 0.8m on concrete: - 6 side - 8 corners	1) No mechanical & appearance damage on the finished product. 2) No product out of their original position.
Take 5 empty trays	70°C 96 hours -20°C 96 hours	No deformation of trays
Damp heat with load	20-40°C, 80-90% HR, 168h, 2 stacked full boxes	No damage to internal products and no major deformation of the trays

4. MARKINGS

Each modules is individually labelled with following instructions :

- TAT07_Rx (x: current revision 0, 1, 2, etc - see §2.1)
- Lot number : Y.WW.SS (Year.Week.Serial number)

For label size and location refer to mechanical drawing (§2.7)

5. SHIPMENT METHOD

5.1 INTERNAL PACKAGING

The products are packaged on ESD safe trays (see tray drawing in Appendix 1), to protect them from touching each other.

Tray dimension is 33.5 x 33.5mm, each tray containing? pcs. Maximum stacking height for sub packages shall be limited to 10 trays + 1 cover tray.

Following information is contained on the label of each subpackage:

1. Lot number
2. P.N. (TAT07_Rx) (see §2.1)
3. Customer P.N. (see §2.1)
4. Quantity of pcs

6. RECEIVING INSPECTION

Receiving inspection at customer site has to be done within 1 month after receipt of the goods. Any products that do not conform to product and delivery specification are dealt with in accordance with item « dealing with customer complaints » in EM General Terms of Sales (see EM website)

7. QUALITY ASSURANCE

Also refer to EM General Terms of Sales and EM Web Site

7.1 CONFORMITY

The performance, functions and reliability of the shipped products conform to the EM product specifications.

7.2 RESPONSIBILITY

Customer is responsible for any defects in quality caused after receiving inspection.

7.3 SHIPPING INSPECTION STANDARDS

7.3.1 *Shipping Inspection Standards*

Sampling size : MIL_STD_105D, single sampling, Inspection level II

RANK	DEFECT	AQL level
Major defect	No display Short circuit Outside dimensions	0.1
Minor defect	Display missing Pattern misalignment Spots, streaks Bubbles Chromaticity and uniformity Polarizer defects Glass defects Dirt, spots Current consumption FPC	0.65

7.3.2 *Zone Definitions*

Shipment inspection is performed under dividing zone A and B.

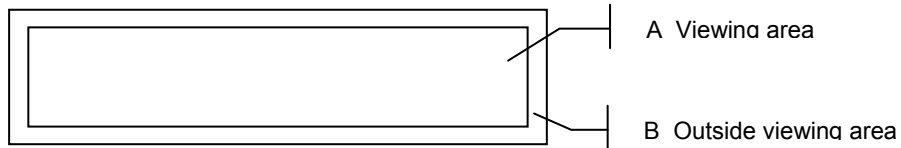

7.3.3 *Visual Inspection*

Inspect under 30W fluorescent lamp, leaving 30cm between panel and eyes, and between panel and lights.

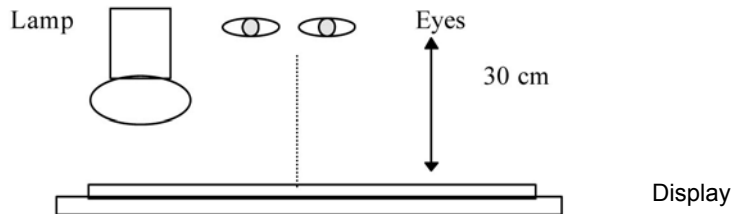

7.3.4 *Limit Sample*

If a judgement cannot be made according to the delivery specification, limit samples must be agreed on and used.



7.3.5 Individual Appearance Defects Standards (Back light ON and OFF / Display OFF)
 Φ Average diameter (mm), W: Width (mm), L: Length (mm)

No	Item	Details	Section	Standards, max no. of defects / module	
				Zone A	Zone B
1	Spots		$< \Phi \leq 0.10$	Any number*	Any number
			$0.10 < \Phi \leq 0.20$	2	
			$0.20 < \Phi \leq$	1	
			Total number of defects	3	
2	Streaks		$W \leq 0.01$	Any number*	Any number
			$W \leq 0.03$ $L \leq 2.0$	2	
			$W \leq 0.05$ $L \leq 1.0$	1	
			Other than above	0	
			Total number of defects	3	
3	Chromaticity and Uniformity	Streaks and uneven colour			limit sample
4	Bubbles in polarizer	Bubbles between polarizer and glass	$0.20 < \Phi \leq 0.50$	3	Any number
			$0.50 < \Phi \leq 1.0$	1	Any number
			$1.0 < \Phi$	0	Any number
			$W \leq 0.15$ $L \leq 5.0$	2	Any number
			$W \leq 0.15$ $L \leq 10.0$	1	Any number
5	Scratches / dent on the polarizer	Spots	$< \Phi \leq 0.10$	Any number*	Any number
			$0.10 < \Phi \leq 0.25$	3	
			$0.25 < \Phi \leq 0.30$	1	
			$0.30 < \Phi$	0	
		Lines	Same as N°2		
6	Dirt on the polarizer				See N.1, 2
7	Polarizer dislocation				Products pass if the dislocation is out of viewing area

* not counted in total number of acceptable defects. Total number of acceptable defects = 3

7.3.6 Individual appearance defects standards (display ON)

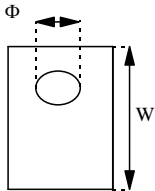
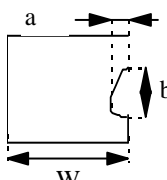
No	Item	Detail	Section (mm)	Standard. Max No of defects / module	
1	No display	Part or all of the screen doesn't light because of an open or a short circuit		Must not occur.	
2	Display missing	Part of display segment missing because of pin holes or an open. 		For W, ref. drawing 2.8	
			$\Phi \leq 0.10$	Any number	
			$0.10 < \Phi \leq 0.20$	2	
			$0.20 < \Phi$	1	
3	Display missing	Part of display segment missing because of pin holes or an open. 	Part missing $\leq 1/3$ of pixel area	3 pixels	

No	Item	Detail	Specification	Standards, max no. of acceptable defects / module
7	Current consumption (Ic)	Condition: - all pixels ON - driving conditions typ. - 25°C	According to table 2.5	0

7.3.7 Chipped Glass Defect Standard

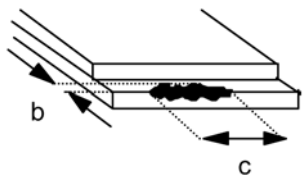
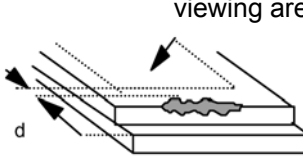
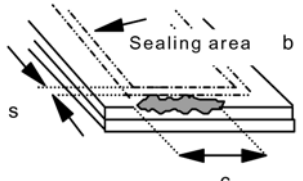
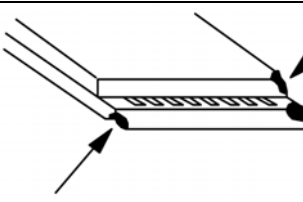
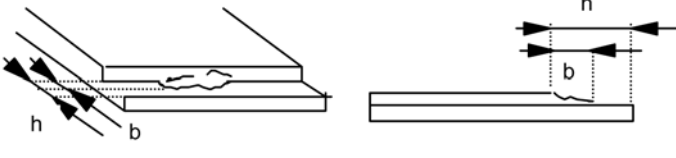
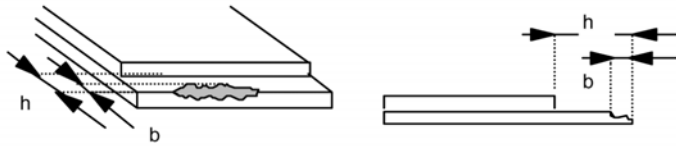
No	Item	Details	Section	Standards, max no. of defects / module
1	Chipped glass at lead terminals			More than 80% of lead terminal must remain
2	Chipped glass excluding terminals			Acceptable if the distance d between chip and the limit of the viewing area is $\geq 0.25\text{mm}$
3	Chipped glass on end face			Width 's' of seal remaining must be $\geq 0.5\text{mm}$; 'c' must be $< 10.0\text{mm}$
4	Chipped glass Other cases			Acceptable if : - 100% of lead terminal remain - 100% of seal remain
5	Glass rest or insulating layer			$b \leq h/3$
6	Irregular cut			$b \leq h/3$ No glass rest

7.3.8 FPC

7.3.8.1. Adhesion

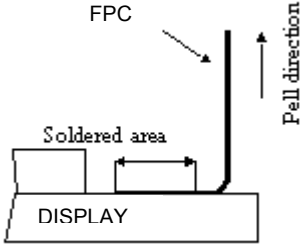
No	Item	Detail	Specification
1	Pull off strength between FPC and Display terminals	Peel off speed = 20mm/minute 	$F_{ave} \geq 500 \text{ N/m}$ Where "F ave" is the average peel off strength obtained in "soldered area" Residue $\geq 50\%$ of bond width
2	Display and FPC terminals misalignment	---	Contact area reduction $\leq 25\%$ of total contact area

7.3.8.2. Characteristics

No	Item	Detail	Specification
1	Outline cable dimension and pattern dimension and layout	---	According to assembly drawing
2	Bubble between base material and coverlayer	---	<ul style="list-style-type: none"> Not acceptable if present on terminals area and on external edge of cable. In other positions, acceptable if diameter \leq distance between 2 adjacent tracks
3	Detachment between track and base material	---	Not allowed
4	Permanent bend and scratch	---	Not allowed



8. OPERATIONS PRECAUTIONS

8.1 SAFETY

- If the display panel breaks, be careful not to get the residues in your mouth or in your eyes.
- If the residues touch your skin or clothes, wash it off using soap and water.

8.2 HANDLING

- The display is plate glass; do not hit or crush it.
- The polarizer of the display is very fragile; handle it very carefully.
- Do not soil or damage the display terminals.
- Keep the display surface clean. Do not touch it with your skin.
- Display module is ESD sensitive, to be handled with usual ESD precautions.

8.3 MOUNTING AND DESIGN

- If any force is applied to the polarizer, bubbles or separation may occur.
- Leave a gap so that the display, excluding the fixing portion, does not touch other components.
- Make a window smaller than the viewing area.
- To protect the display from external pressure, place a transparent plate (acrylic or glass) over the display surface having a small gap.
- Avoid condensation, otherwise the transparent electrodes may break.

8.4 STORAGE

- For long-time storage, keep in a dark place at $25^{\circ}\text{C} \pm 10^{\circ}\text{C}$, 65% RH maximum.
- Do not store the display near organic solvents or corrosive gases.

8.5 CLEANING

- Do not wipe the polarizing plate with a dry cloth, as it may scratch the surface.
- Wipe the module gently with a soft cloth soaked with a perfluorine-hexane or iso-propanol.
- Do not use ketonic solvents (ketone and acetone) or aromatic solvents (toluene and xylene), as they may damage the plastic cover plate.



9. APPENDIX 1: PLASTIC TRAY DRAWING

- Drawing to be done
- Tray dimensions: 335 x 335 x 11.8
- ESD safe material
- Vacuum forming technology



11. SPECIFICATION HISTORY

Rev.	E.C.N.	Pages	Date	Resp.	Description
A	07-0287	17	27.03.07	LON	1 st revision
B	08-0301	3	04.04.08	FABR	Updated value in point 2.5 electrical characteristics

12. ATTACHMENTS

Minispecs:	-
Forms:	-

13. CUSTOMER APPROVAL

Should EM not have received a written feed-back from you within 10 days from receipt of the above specification(s), such specification(s) shall be explicitly considered as approved and accepted by you.

Customer (print company name): _____

Approved by (print name): _____

Signature: _____

Title: _____

Date: _____

Please complete and return to:

**LCD & Module Department
EM Microelectronic SA
Rue des Sors 3
CH-2074 Marin**

Fax: +41 32 755 5918