

Reset Circuit with Adjustable Delay

Description

The EM6354 is an ultra-low current reset circuit available in a large variety of configurations and very small packages for maximum flexibility in all end-applications up to 125°C and using power supplies between 1.5V and 5.5V.

This circuit monitors the supply voltage of any electronic system, and generates the appropriate reset signal. The threshold defines the minimum allowed voltage which guarantees the good functionality of the system. When V_{DD} rises above V_{TH} , the output remains active for an additional delay time. This allows the system to stabilize before going fully active. This delay time, or reset timeout period, can be adjusted using an external capacitor.

The output is guaranteed to be in the correct state for V_{DD} down to 0.8V. There are 11 reset threshold voltages starting as low as 1.31V and up to 4.63V. The EM6354 features three output types: active-low push-pull, active-low open-drain and active-high push-pull.

Small SC70 and SOT23 packages as well as ultra-low supply current of 2.9µA make the EM6354 an ideal choice for portable and battery-operated devices.

Typical Application

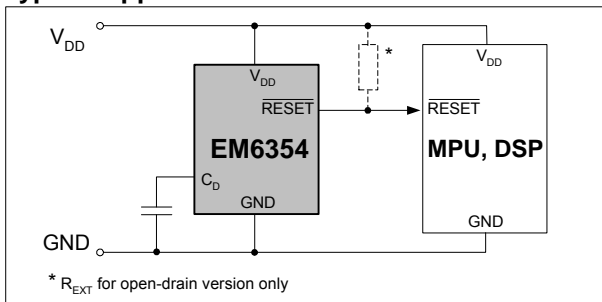

Pin Configuration (top view)

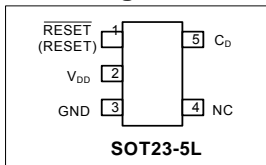

Pin Description

Pin	Name	Function
1	$\overline{\text{RESET}}$	Active-low $\overline{\text{RESET}}$ output. $\overline{\text{RESET}}$ remains low for the reset timeout period after all reset conditions are deasserted and then goes high.
	RESET	Active-high RESET output. RESET remains high for the reset timeout period after all reset conditions are deasserted and then goes low.
2	V_{DD}	Supply Voltage (5.5V max.)
3	GND	Ground
4	N.C.	Not connected. Not internally connected
5	C_D	Connect a capacitor between C_D and GND to set the timeout period (C_D min=1nF; C_D max=1000nF). Reset Timeout Period in [ms] is equal to C_D in [nF]

Features

- Adjustable reset timeout period using an external capacitor
- Ultra-low supply current of 2.9µA ($V_{DD}=3.3V$)
- Operating temperature range: -40°C to +125°C
- ±1.5% reset threshold accuracy
- 11 reset threshold voltages V_{TH} : 4.63V, 4.4V, 3.08V, 2.93V, 2.63V, 2.2V, 1.8V, 1.66V, 1.57V, 1.38V, 1.31V
- 3 reset output options:
 - Active-low $\overline{\text{RESET}}$ push-pull
 - Active-low $\overline{\text{RESET}}$ open-drain
 - Active-high RESET push-pull
- Immune to short negative V_{DD} transients
- Guaranteed Reset valid down to 0.8V
- Threshold hysteresis: 2.1% of V_{TH}
- Very small SOT23-5L package

Applications

- Home appliances
- Modems
- Routers, hubs and gateways
- WAN, LAN
- Handheld GPS
- Metering and Instrumentation
- TV sets

Block Diagram

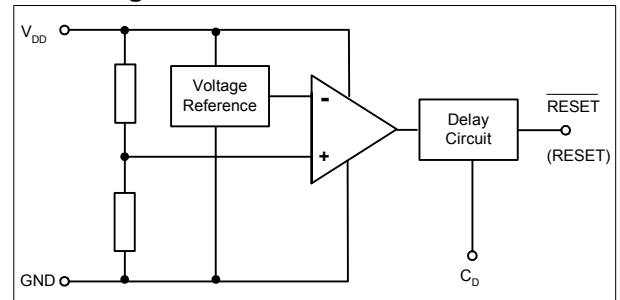



Ordering Information

EM6354 X SP5B - 2.9 +

Reset Output Type:

X = Active-low /RES push-pull
Y = Active-low /RES open-drain
Z = Active-high RES push-pull

Package:

SP5B = SOT23-5, Tape&Reel 3000 pcs

RoHS Compliance:

+ = lead-free/green mold compliant
[blank] = leaded

Reset Threshold Voltage (V_{TH}):

1.3 = 1.31V	2.6 = 2.63V
1.4 = 1.38V	2.9 = 2.93V
1.6 = 1.57V	3.1 = 3.08V
1.7 = 1.66V	4.4 = 4.40V
1.8 = 1.80V	4.6 = 4.63V
2.2 = 2.20V	

Note: subject to availability (see standard versions list below). Please give complete Part Number when ordering.

Standard Versions (Top Marking)

Part Number	Top Marking ¹⁾	Top Marking ²⁾ with 4 Characters
EM6354XSP5B-2.9+	KA##	BMAH
EM6354YSP5B-4.6+	K1##	BMAX

¹⁾ Top marking is the standard from 2006. No bottom marking exists. Where ## refers to the lot number (EM internal reference only)

²⁾ Top marking with 4 characters is standard from 2003. For lead-free/green mold (RoHS) parts, the first letter of top marking with 4 characters begins with letter "B" instead of letter "A". Bottom marking indicates the lot number.

Standard Versions (samples)

Part Number
EM6354XSP5B-2.9+
EM6354YSP5B-4.6+

Sample stock is generally held on **standard versions** only. Please contact factory for other versions not shown here and for availability of non standard versions.



Absolute Maximum Ratings

Parameter	Symbol	Conditions
Voltage at V _{DD} to GND	V _{DD}	-0.3V to +6V
Minimum voltage at any signal pin	V _{MIN}	GND - 0.3V
Maximum voltage at any signal pin	V _{MAX}	V _{DD} + 0.3V
Electrostatic discharge max. to MIL-STD-883C method 3015.7 with ref. to V _{SS}	V _{ESD}	2000V
Max. soldering conditions	T _{MAX}	250°C x 10s
Storage Temperature Range	T _{STG}	-65°C to +150°C

Stresses above these listed maximum ratings may cause permanent damages to the device. Exposure beyond specified operating conditions may affect device reliability or cause malfunction.

Handling Procedures

This device has built-in protection against high static voltages or electric fields; however, anti-static precautions must be taken as for any other CMOS component. Unless otherwise specified, proper operation can only occur when all terminal voltages are kept within the voltage range. Unused inputs must always be tied to a defined logic voltage level.

Operating Conditions

Parameter	Symbol	Min	Max	Unit
Supply voltage (note 1)	V _{DD}	0.8	5.5	V
Operating Temperature	T _A	-40	+125	°C

Electrical Characteristics

Unless otherwise specified: V_{DD}= 0.8V to 5.5V, T_A=+25°C (note 1).

Parameter	Symbol	Conditions	Min	Typ	Max	Unit	
Supply current (note 2)	I _{DD}	V _{DD} =1.5V	+25°C	-	2.3	4.6	μA
			-40°C to +125°C	-	-	7	
		V _{DD} =3.3V	+25°C	-	2.9	5.5	
			-40°C to +125°C	-	-	8.3	
		V _{DD} =5.0V	+25°C	-	3.4	6.3	
			-40°C to +125°C	-	-	9.6	
Threshold voltage (note 3)	V _{TH}	EM6354 – 1.3	1.290	1.31	1.330	V	
		EM6354 – 1.4	1.359	1.38	1.401		
		EM6354 – 1.6	1.546	1.57	1.594		
		EM6354 – 1.7	1.635	1.66	1.685		
		EM6354 – 1.8	1.773	1.80	1.827		
		EM6354 – 2.2	2.167	2.20	2.233		
		EM6354 – 2.6	2.591	2.63	2.669		
		EM6354 – 2.9	2.886	2.93	2.974		
		EM6354 – 3.1	3.034	3.08	3.126		
		EM6354 – 4.4	4.334	4.40	4.466		
EM6354 – 4.6	4.561	4.63	4.699				
Threshold voltage temperature coefficient (note 4)	$\frac{\Delta V_{TH}}{\Delta T_A}$	T _A = -40°C to +125°C	-	±50	-	ppm/°C	
Threshold hysteresis	V _{HYS}		-	2.1%·V _{TH}	-	V	

Note 1: Production tested at +25°C only. Over temperature limits are guaranteed by design, not production tested. V_{DD} min=0.9V for active-high versions (EM6354Z).

Note 2: RESET (RESET) open.

Note 3: Threshold voltage is specified for V_{DD} falling.

Note 4: Typical variation ΔV_{TH} of V_{TH} at a given temperature T_A is calculated as follows:

$$\Delta V_{TH}(T = T_A) = \frac{\Delta V_{TH}}{\Delta T_A} \times V_{TH} \times |T_A - 25^\circ\text{C}|$$

Example:

for version V_{TH}=2.93V, variation at T_A=70°C is equal to ΔV_{TH}(70°C)=±50·10⁻⁶ x 2.93 x (70-25)=±6.59mV

Electrical Characteristics (continued)

Unless otherwise specified: $V_{DD} = 0.8V$ to $5.5V$, $T_A = +25^\circ C$ (note 1).

Parameter	Symbol	Conditions		Min	Typ	Max	Unit
Reset timeout period	t_{POR}	$C_D = 100nF$ (measured value, note 5) V_{DD} from $0V$ to $V_{TH (typ)} + 15\%$ (note 2) EM6354-4.6 version		72	100	122	ms
Propagation delay time V_{DD} to \overline{RESET} (RESET) delay	t_P	V_{DD} drops from $V_{TH (typ)} + 0.2V$ to $V_{TH (typ)} - 0.2V$ (note 2)		2	130	255	μs
Open-drain \overline{RESET} output Voltage	V_{OL}	$-40^\circ C$ to $+125^\circ C$	$V_{DD} > 1V$ $I_{OL} = 100\mu A$	-	-	0.3	V
			$V_{DD} > 2.5V$ $I_{OL} = 1.5mA$	-	-	0.3	
			$V_{DD} > 5V$ $I_{OL} = 3mA$	-	-	0.3	
Push-pull \overline{RESET} / \overline{RESET} Output voltage	V_{OL}	$-40^\circ C$ to $+125^\circ C$	$V_{DD} > 1V$ $I_{OL} = 100\mu A$	-	-	0.3	V
			$V_{DD} > 2.5V$ $I_{OL} = 1.5mA$	-	-	0.3	
			$V_{DD} > 5V$ $I_{OL} = 3mA$	-	-	0.3	
	V_{OH}	$-40^\circ C$ to $+125^\circ C$	$V_{DD} > 1V$ $I_{OH} = -30\mu A$	0.8	-	-	
			$V_{DD} > 2.5V$ $I_{OH} = -1.5mA$	2	-	-	
			$V_{DD} > 5V$ $I_{OH} = -3mA$	4	-	-	
Output leakage current	I_{LEAK}	$-40^\circ C$ to $+125^\circ C$, only for EM6354Y (open-drain)		-	-	0.5	μA

Note 1: Production tested at $+25^\circ C$ only. Over temperature limits are guaranteed by design, not production tested.
 $V_{DD \text{ min}} = 0.9V$ for active-high version (EM6354Z).

Note 2: \overline{RESET} (RESET) open.

Note 5: t_{POR} is programmable by varying the value of the external capacitor connected to pin C_D . The relation is $t_{POR} (ms) = C_D (nF)$. The tolerance of the capacitor should be taken into account.

Timing Waveforms

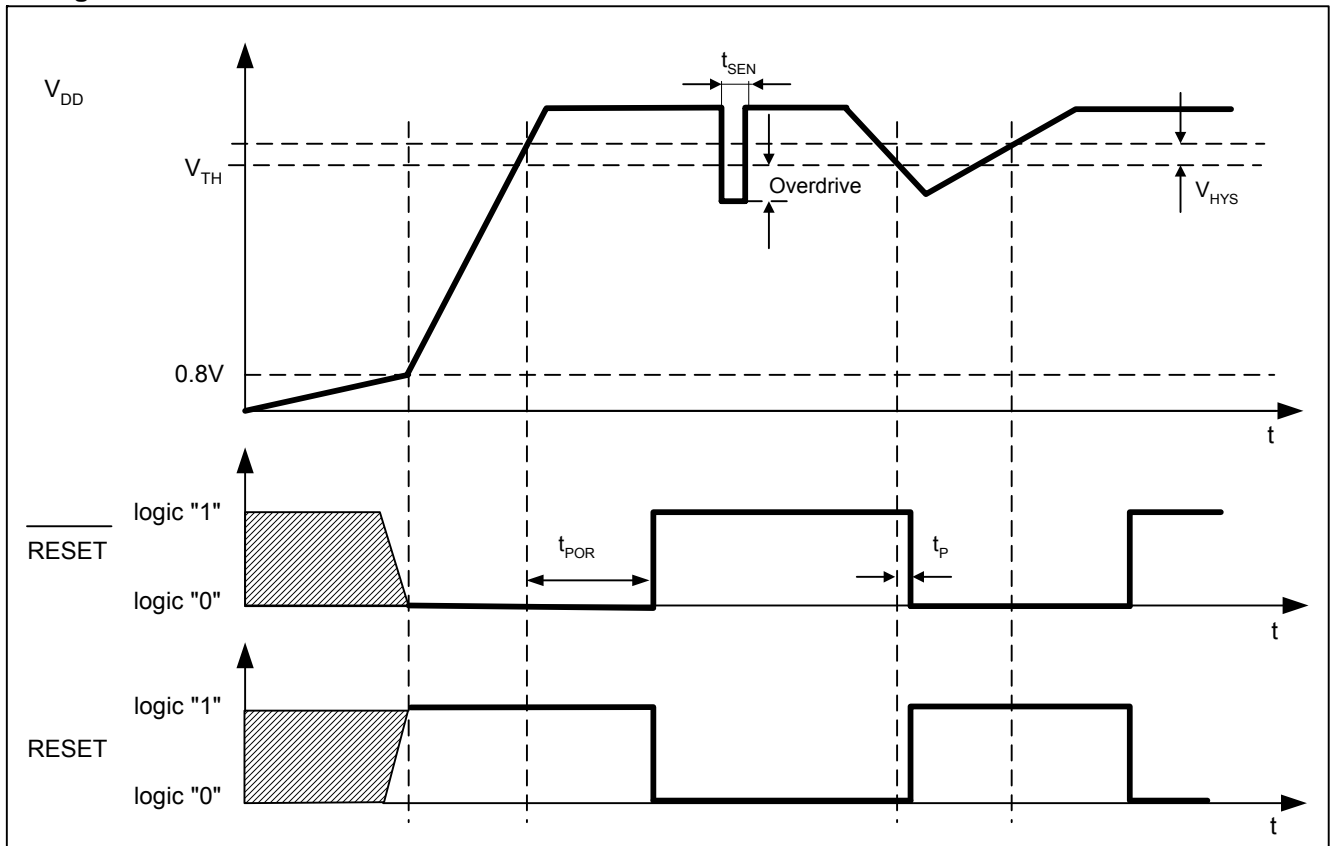

Note 6: t_{SEN} = Maximum Transient Duration. Please refer to figure on the next page.

Note 7: Overdrive = $V_{TH} - V_{DD}$. Please refer to figure on the next page.

Typical Reset Timeout Period

The Reset Timeout Period (t_{POR}) is programmable using an external capacitor connected to pin C_D of EM6354. A ceramic chip capacitor rated at or above 10V is sufficient. The Reset Timeout Period (t_{POR}) can be calculated using the following formula for $V_{TH}=4.63V$ (EM6354-4.6):

$$t_{POR} \text{ (ms)} = C_D \text{ (nF)}.$$

For example a C_D of 100nF will achieve a t_{POR} of 100 ms. The tolerance of the capacitor should be taken into account. If no delay due to t_{POR} is needed in a certain application, the circuit EM6352 should be used instead.

For threshold voltage between $V_{TH}=4.63V$ and $V_{TH}=1.31V$, the following graphic applies :

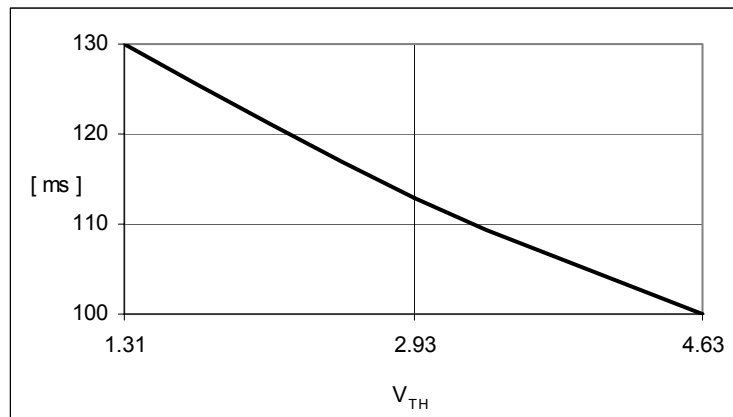

Typical Reset Timeout Period t_{POR} vs. V_{TH} for $C_D=100\text{nF}$ at $T_A=+25^\circ\text{C}$

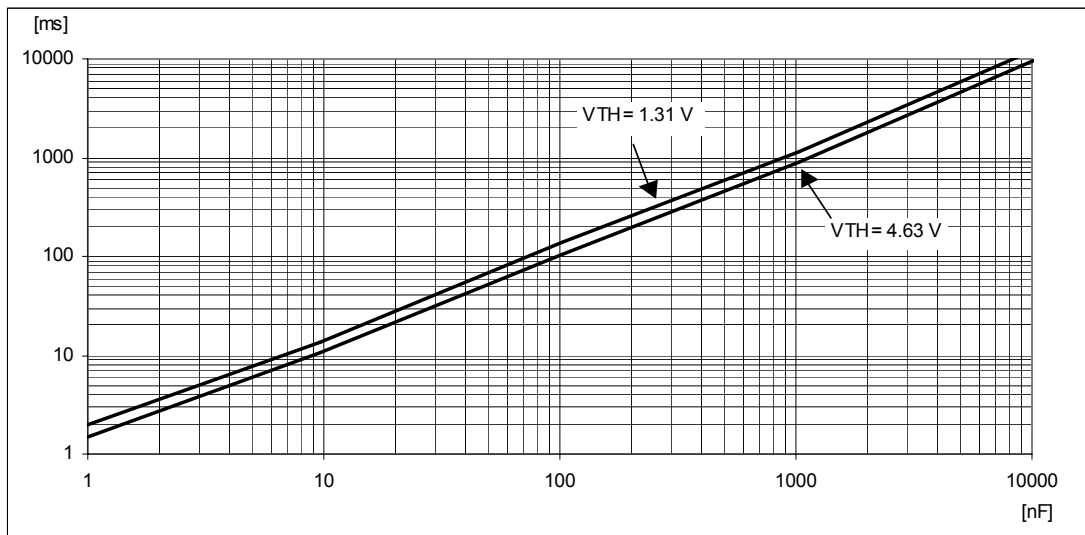

Reset Timeout Period t_{POR} vs. Capacitor C_D at $T_A=+25^\circ\text{C}$

Typical Operating Characteristics

(Typical values are at $T_A=+25^\circ\text{C}$ unless otherwise noted, $\overline{\text{RESET}}$ or RESET open.)

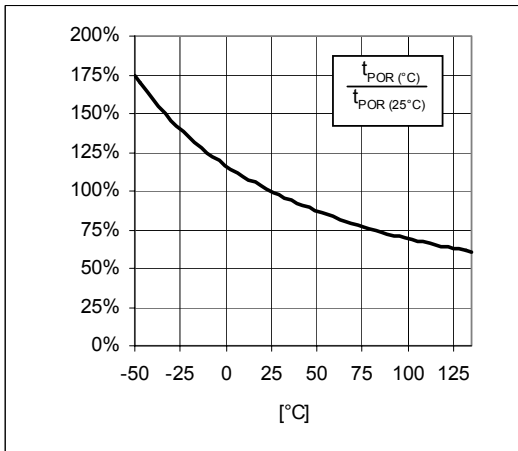

Reset Timeout Period t_{POR} vs. Temperature (normalized with respect to t_{POR} 25 $^{\circ}\text{C}$)

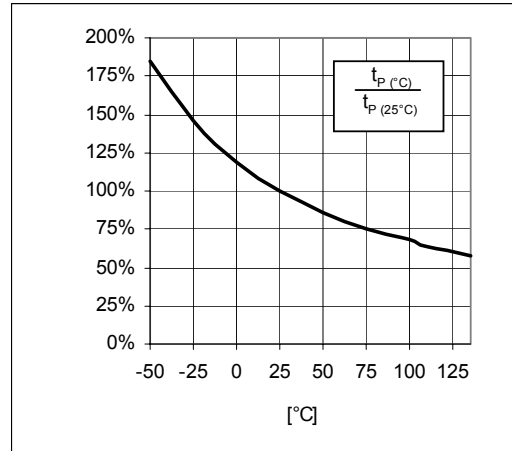

Propagation Time t_P vs. Temperature (normalized with respect to t_P 25 $^{\circ}\text{C}$)

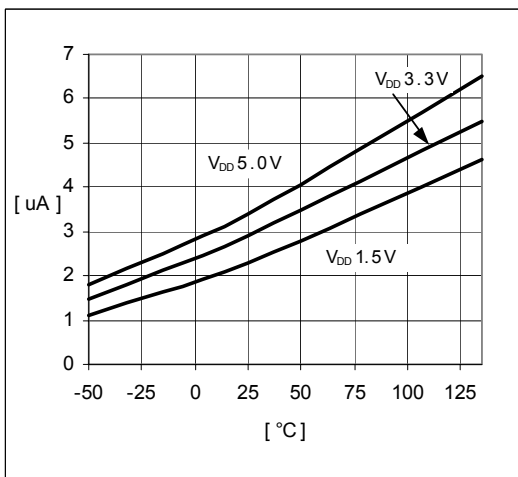

I_{DD} vs. Temperature

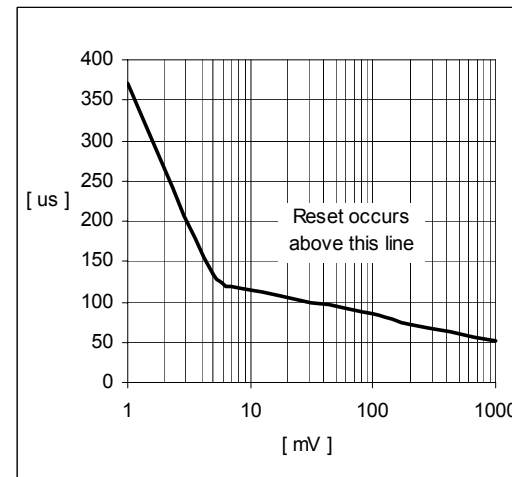

Maximum Transient Duration t_{SEN} vs. Overdrive $V_{TH}-V_{DD}$

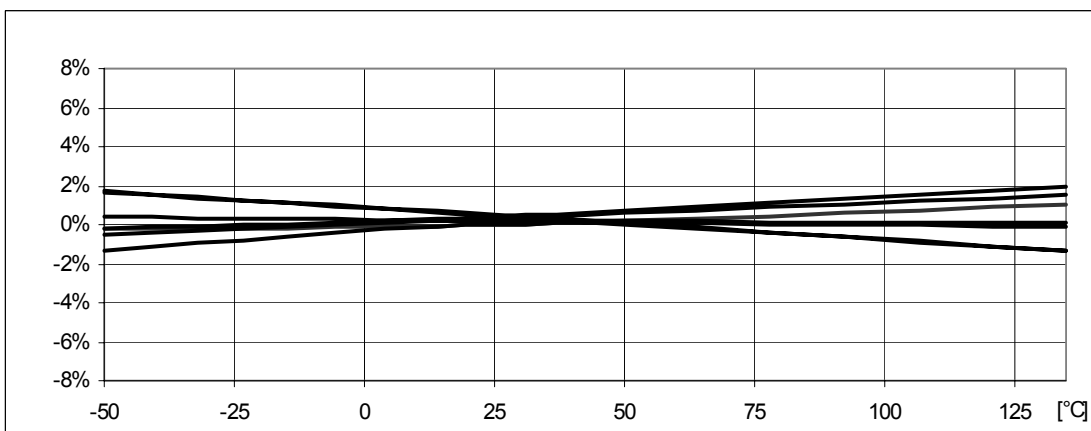

Threshold Voltage Variation vs. Temperature (normalized)

Package Information

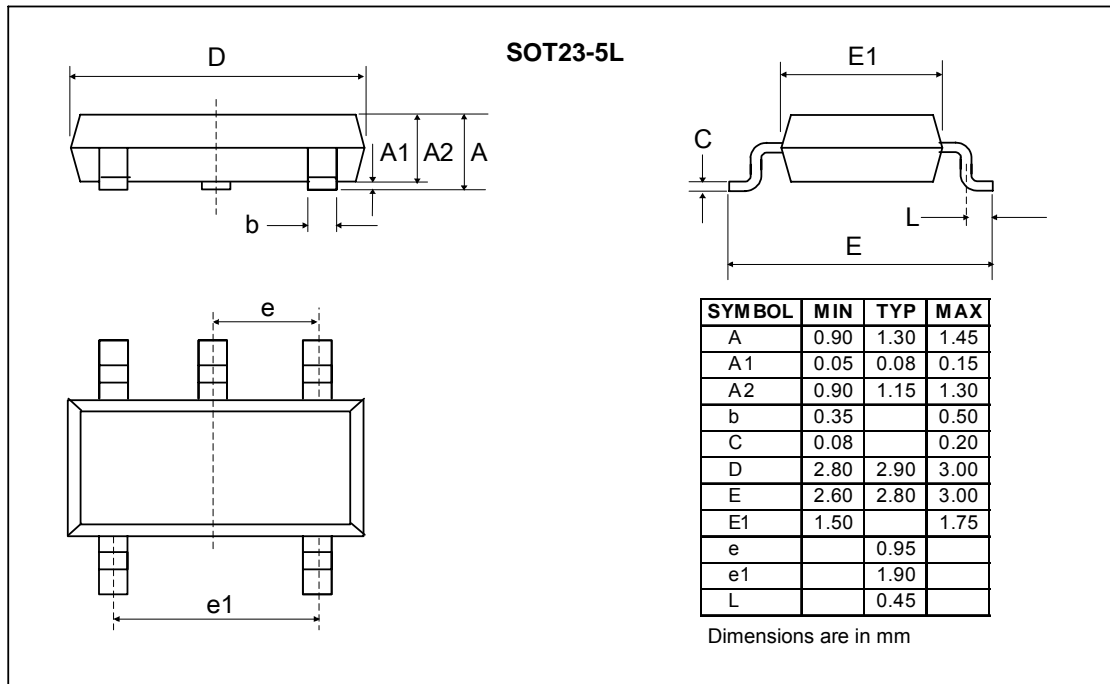

Traceability for small packages

Due to the limited space on the package surface, the bottom marking contains a limited number of characters that provide only partial information for lot traceability. Full information for complete traceability is however provided on the packing labels of the product at delivery from EM. It is highly recommended that the customer insures full lot traceability of EM product in his final product.

EM Microelectronic-Marin SA (EM) makes no warranty for the use of its products, other than those expressly contained in the Company's standard warranty which is detailed in EM's General Terms of Sale located on the Company's web site. EM assumes no responsibility for any errors which may appear in this document, reserves the right to change devices or specifications detailed herein at any time without notice, and does not make any commitment to update the information contained herein. No licenses to patents or other intellectual property of EM are granted in connection with the sale of EM products, expressly or by implications. EM's products are not authorized for use as components in life support devices or systems.

Product qualification is performed according to internal EM quality standards for industrial products. For any special requirement (eg. automotive grade) please contact EM Microelectronic-Marin S.A.