



Reset Circuit with Fixed Delay

Description

The EM6353 is an ultra-low current reset circuit available in a large variety of configurations and very small packages for maximum flexibility in all end-applications up to 125°C and using power supplies between 1.5V and 5.5V.

This circuit monitors the supply voltage of any electronic system, and generates the appropriate reset signal after a fixed reset timeout period. The threshold defines the minimum allowed voltage which guarantees the good functionality of the system. When V_{DD} rises above V_{TH} , the output remains active for an additional delay time. This allows the system to stabilize before getting fully active.

The EM6353 features three output types: active-low push-pull, active-low open-drain and active-high push-pull.

Small SC70-5L and SOT23-3L packages as well as ultra-low supply current of 2.9µA make the EM6353 an ideal choice for portable and battery-operated devices.

Typical Application

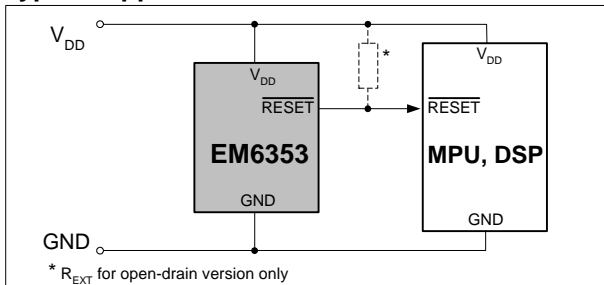

Pin Configuration (top view)

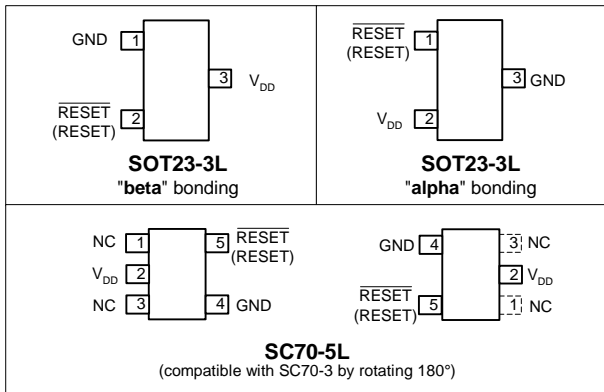

Pin Description

Pin			Name	Function
SOT23-3L "beta"	SOT23-3L "alpha"	SC70-5L		
1	3	4	GND	Ground
2	1	5	$\overline{\text{RESET}}$	Active-low $\overline{\text{RESET}}$ output. $\overline{\text{RESET}}$ remains low for the reset timeout period after all reset conditions are deasserted and then goes high.
			RESET	Active-high RESET output. RESET remains high for the reset timeout period after all reset conditions are deasserted and then goes low.
3	2	2	V_{DD}	Supply Voltage (5.5V max.)
-	-	1,3	N.C.	Not connected. Not internally connected.

Features

- ❑ 200ms reset timeout period (25ms on request)
- ❑ Ultra-low supply current of 2.9µA ($V_{DD}=3.3V$)
- ❑ Operating temperature range: -40°C to +125°C
- ❑ ±1.5% reset threshold accuracy
- ❑ 11 reset threshold voltages V_{TH} : 4.63V, 4.4V, 3.08V, 2.93V, 2.63V, 2.2V, 1.8V, 1.66V, 1.57V, 1.38V, 1.31V
- ❑ 3 reset output options:
 - Active-low $\overline{\text{RESET}}$ push-pull
 - Active-low $\overline{\text{RESET}}$ open-drain
 - Active-high RESET push-pull
- ❑ No external components
- ❑ Immune to short negative V_{DD} transients
- ❑ Guaranteed Reset valid down to 0.8V
- ❑ Threshold hysteresis: 2.1% of V_{TH}
- ❑ Very small SOT23-3L and SC70-5L packages

Applications

- ❑ Mobile phones
- ❑ Set-top boxes
- ❑ Video, digital cameras, DVD players and recorders
- ❑ Modems
- ❑ Personal computers
- ❑ Switching hubs
- ❑ Copiers and fax
- ❑ Utility meters

Block Diagram

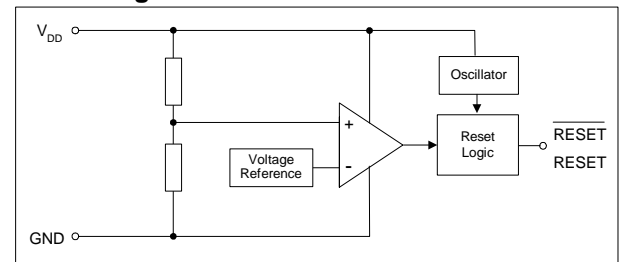



Ordering Information

<p>Delay (t_{POR}): B = 200ms A = 25ms</p> <p>Reset Output Type: X = Active-low /RES push-pull Y = Active-low /RES open-drain Z = Active-high RES push-pull</p> <p>Package & Bonding: 1SP3B = SOT23-3, "alpha", Tape&Reel 3kpcs 2SP3B = SOT23-3, "beta", Tape&Reel 3kpcs SC5B = SC70-5, Tape&Reel 3kpcs</p>	<p>RoHS Compliance: + = lead-free/green mold compliant [blank] = leaded</p> <p>Reset Threshold Voltage (V_{TH}):</p> <table border="0"> <tr><td>1.3 = 1.31V</td><td>2.6 = 2.63V</td></tr> <tr><td>1.4 = 1.38V</td><td>2.9 = 2.93V</td></tr> <tr><td>1.6 = 1.57V</td><td>3.1 = 3.08V</td></tr> <tr><td>1.7 = 1.66V</td><td>4.4 = 4.40V</td></tr> <tr><td>1.8 = 1.80V</td><td>4.6 = 4.63V</td></tr> <tr><td>2.2 = 2.20V</td><td></td></tr> </table>	1.3 = 1.31V	2.6 = 2.63V	1.4 = 1.38V	2.9 = 2.93V	1.6 = 1.57V	3.1 = 3.08V	1.7 = 1.66V	4.4 = 4.40V	1.8 = 1.80V	4.6 = 4.63V	2.2 = 2.20V	
1.3 = 1.31V	2.6 = 2.63V												
1.4 = 1.38V	2.9 = 2.93V												
1.6 = 1.57V	3.1 = 3.08V												
1.7 = 1.66V	4.4 = 4.40V												
1.8 = 1.80V	4.6 = 4.63V												
2.2 = 2.20V													

Note: Subject to availability (see standard versions list below). Please give complete Part Number when ordering. All parts are offered in tape-and-reel only (3000 units).

Standard Versions (Top Marking)

Part Number	Top Marking ¹⁾	Top Marking ²⁾ with 4 Characters
EM6353BX2SP3B-3.1+	C5##	BLWJ
EM6353BXSC5B-3.1+	C5##	BLWJ
EM6353BY2SP3B-3.1+		BLWV
EM6353BZ2SP3B-3.1+		BLW7
EM6353BX1SP3B-4.4+	C2##	BLBK
EM6353BX2SP3B-4.4+	C8##	BLWK
EM6353BX1SP3B-2.6+		BLBG
EM6353BX2SP3B-2.6+	BW##	BLWG
EM6353BXSC5B-2.6+	BW##	BLWG
EM6353BY2SP3B-2.6+	C9##	BLWT
EM6353BX1SP3B-4.6+		BLBL

Part Number	Top Marking ¹⁾	Top Marking ²⁾ with 4 Characters
EM6353BX2SP3B-4.6+		BLWL
EM6353BY2SP3B-4.6+		BLWX
EM6353BZ2SP3B-4.6+	CB##	BLW9
EM6353BX2SP3B-1.8+		BLWE
EM6353BX1SP3B-2.9+	C1##	BLBH
EM6353BX2SP3B-2.9+	BR##	BLWH
EM6353BY1SP3B-2.9+	BS##	BLBU
EM6353BY2SP3B-2.9+	C7##	BLWU
EM6353BYSC5B-2.9+	C7##	BLWU
EM6353BZ2SP3B-2.9+	BV##	BLW6

¹⁾ Top marking is the standard from 2006. No bottom marking exists. Where ## refers to the lot number (EM internal reference only)

²⁾ Top marking with 4 characters is standard from 2003. For lead-free/green mold (RoHS) parts, the first letter of top marking with 4 characters begins with letter "B" instead of letter "A". Bottom marking indicates the lot number.

Standard Versions (Samples)

Part Number
EM6353BX2SP3B-3.1+
EM6353BXSC5B-3.1+
EM6353BY2SP3B-3.1+
EM6353BZ2SP3B-3.1+
EM6353BX1SP3B-4.4+
EM6353BX2SP3B-4.4+
EM6353BX1SP3B-2.6+
EM6353BX2SP3B-2.6+
EM6353BXSC5B-2.6+
EM6353BY2SP3B-2.6+
EM6353BX1SP3B-4.6+

Part Number
EM6353BX2SP3B-4.6+
EM6353BY2SP3B-4.6+
EM6353BZ2SP3B-4.6+
EM6353BX2SP3B-1.8+
EM6353BX1SP3B-2.9+
EM6353BX2SP3B-2.9+
EM6353BY1SP3B-2.9+
EM6353BY2SP3B-2.9+
EM6353BYSC5B-2.9+
EM6353BZ2SP3B-2.9+

Sample stock is generally held on **standard versions** only. Please contact factory for other versions not shown here and for availability of non standard versions.



Absolute Maximum Ratings

Parameter	Symbol	Conditions
Voltage at V_{DD} to GND	V_{DD}	-0.3V to +6V
Minimum voltage at any signal pin	V_{MIN}	GND - 0.3V
Maximum voltage at any signal pin	V_{MAX}	$V_{DD} + 0.3V$
Electrostatic discharge max. to MIL-STD-883C method 3015.7 with ref. to V_{SS}	V_{ESD}	2000V
Max. soldering conditions	T_{MAX}	250°C x 10s
Storage Temperature Range	T_{STG}	-65°C to +150°C

Stresses above these listed maximum ratings may cause permanent damage to the device. Exposure beyond specified operating conditions may affect device reliability or cause malfunction.

Electrical Characteristics

Unless otherwise specified: V_{DD} = 0.8V to 5.5V, T_A =-40°C to +125°C (note 1).

Parameter	Symbol	Conditions	Min	Typ	Max	Unit	
Supply current (note 2)	I_{DD}	$V_{DD}=1.5V$	+25°C	-	2.3	4.6	μA
			-40°C to +125°C	-	-	7	
		$V_{DD}=3.3V$	+25°C	-	2.9	5.5	
			-40°C to +125°C	-	-	8.3	
		$V_{DD}=5.0V$	+25°C	-	3.4	6.3	
			-40°C to +125°C	-	-	9.6	
Threshold voltage (note 3)	V_{TH}	EM6353 – 1.3	+25°C	1.290	1.31	1.330	V
			-40°C to +85°C	1.245		1.382	
			-40°C to +125°C	1.221		1.387	
		EM6353 – 1.4	+25°C	1.359	1.38	1.401	
			-40°C to +85°C	1.311		1.456	
			-40°C to +125°C	1.286		1.461	
		EM6353 – 1.6	+25°C	1.546	1.57	1.594	
			-40°C to +85°C	1.492		1.656	
			-40°C to +125°C	1.463		1.663	
		EM6353 – 1.7	+25°C	1.635	1.66	1.685	
			-40°C to +85°C	1.577		1.751	
			-40°C to +125°C	1.547		1.758	
		EM6353 – 1.8	+25°C	1.773	1.80	1.827	
			-40°C to +85°C	1.710		1.899	
			-40°C to +125°C	1.678		1.906	
		EM6353 – 2.2	+25°C	2.167	2.20	2.233	
			-40°C to +85°C	2.090		2.321	
			-40°C to +125°C	2.050		2.330	
		EM6353 – 2.6	+25°C	2.591	2.63	2.669	
			-40°C to +85°C	2.499		2.775	
			-40°C to +125°C	2.451		2.785	
		EM6353 – 2.9	+25°C	2.886	2.93	2.974	
			-40°C to +85°C	2.784		3.091	
			-40°C to +125°C	2.731		3.103	
EM6353 – 3.1	+25°C	3.034	3.08	3.126			
	-40°C to +85°C	2.926		3.249			
	-40°C to +125°C	2.871		3.262			
EM6353 – 4.4	+25°C	4.334	4.40	4.466			
	-40°C to +85°C	4.180		4.642			
	-40°C to +125°C	4.101		4.660			
EM6353 – 4.6	+25°C	4.561	4.63	4.699			
	-40°C to +85°C	4.399		4.885			
	-40°C to +125°C	4.315		4.903			
Threshold hysteresis	V_{HYS}	$T_A=+25^\circ C$	-	$2.1\% \cdot V_{TH}$	-	V	

Note 1: Production tested at +25°C only. Over temperature limits are guaranteed by design, not production tested.
 V_{DD} min=0.9V for active-high versions (EM6353_Z).

Note 3: Threshold voltage is specified for V_{DD} falling.

Handling Procedures

This device has built-in protection against high static voltages or electric fields; however, anti-static precautions must be taken as for any other CMOS component. Unless otherwise specified, proper operation can only occur when all terminal voltages are kept within the voltage range. Unused inputs must always be tied to a defined logic voltage level.

Operating Conditions

Parameter	Symbol	Min	Max	Unit
Supply voltage (note 1)	V_{DD}	0.8	5.5	V
Operating Temperature	T_A	-40	+125	°C



Electrical Characteristics (continued)

Unless otherwise specified: $V_{DD} = 0.8V$ to $5.5V$, $T_A = -40^{\circ}C$ to $+125^{\circ}C$ (note 1).

Parameter	Symbol	Conditions	Min	Typ	Max	Unit	
Reset timeout period	t_{POR}	V_{DD} from $0V$ to $V_{TH(typ)} + 15\%$ (note 2 and 4). $T_A = +25^{\circ}C$	EM6353B	155	200	224	ms
			EM6353A	19.4	25	28	
Propagation delay time V_{DD} to \overline{RESET} (RESET) delay	t_P	V_{DD} drops from $V_{TH(typ)} + 0.2V$ to $V_{TH(typ)} - 0.2V$ (note 2). $T_A = +25^{\circ}C$	2	130	255	μs	
Open-drain \overline{RESET} output Voltage	V_{OL}	$V_{DD} > 1V$	$I_{OL} = 100\mu A$	-	-	0.3	V
		$V_{DD} > 2.5V$	$I_{OL} = 1.5mA$	-	-	0.3	
		$V_{DD} > 5V$	$I_{OL} = 3mA$	-	-	0.3	
Push-pull \overline{RESET} / \overline{RESET} Output voltage	V_{OL}	$V_{DD} > 1V$	$I_{OL} = 100\mu A$	-	-	0.3	V
		$V_{DD} > 2.5V$	$I_{OL} = 1.5mA$	-	-	0.3	
		$V_{DD} > 5V$	$I_{OL} = 3mA$	-	-	0.35	
	V_{OH}	$V_{DD} > 1V$	$I_{OH} = -30\mu A$	0.8	-	-	
		$V_{DD} > 2.5V$	$I_{OH} = -1.5mA$	2	-	-	
		$V_{DD} > 5V$	$I_{OH} = -3mA$	4	-	-	
Output leakage current	I_{LEAK}	Only for EM6353_Y (open-drain)	-	-	0.5	μA	

Note 1: Production tested at $+25^{\circ}C$ only. Over temperature limits are guaranteed by design, not production tested. $V_{DD \text{ min}} = 0.9V$ for active-high versions (EM6353_Z).

Note 2: \overline{RESET} (RESET) open.

Note 4: Standard version is EM6353B ($t_{POR} = 200ms$), available at all times. EM6353A ($t_{POR} = 25ms$) is available by mask option and upon minimum order quantity. Please contact EM sales.

Timing Waveforms

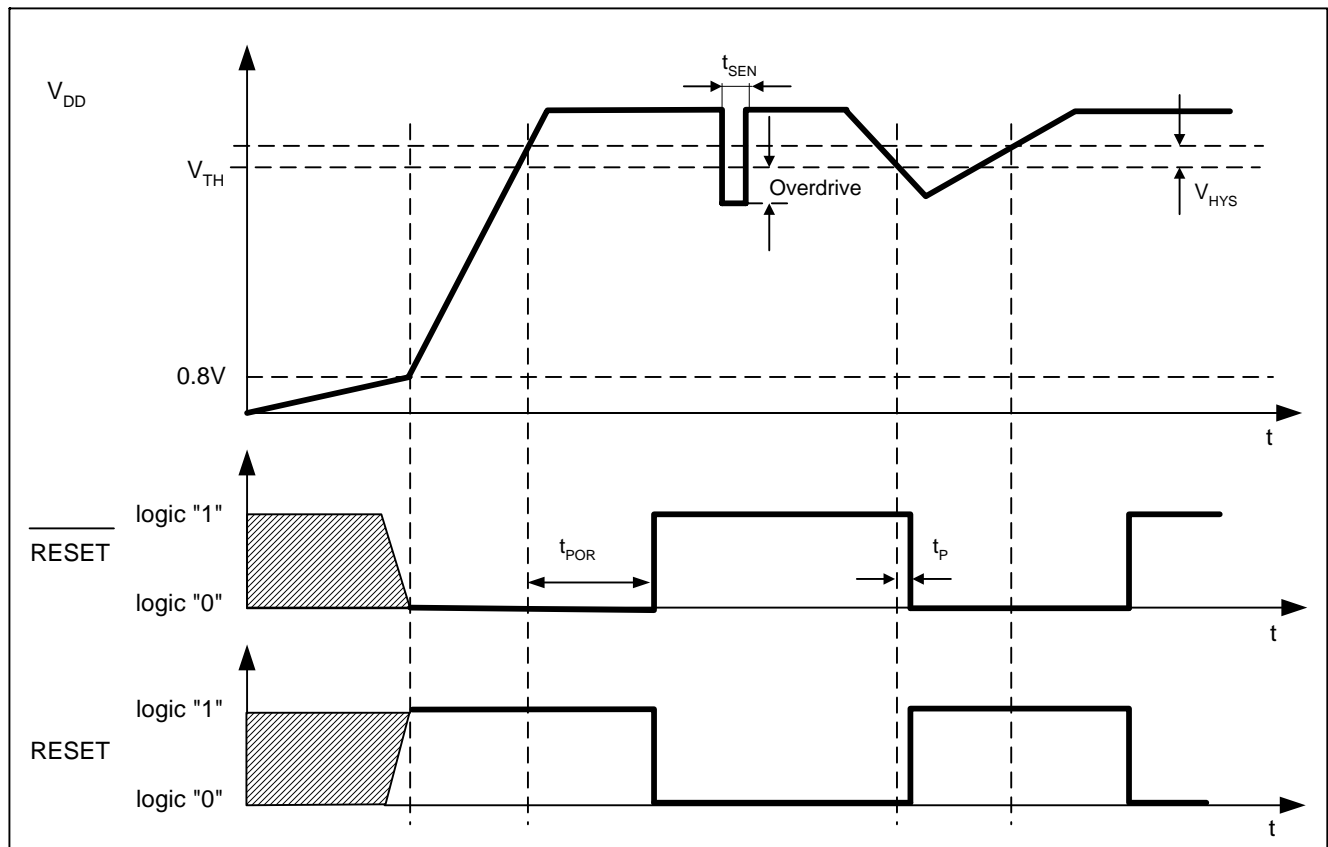

Note 6: t_{SEN} = Maximum Transient Duration. Please refer to figure on next page.

Note 7: Overdrive = $V_{TH} - V_{DD}$. Please refer to figure on next page.



Typical Operating Characteristics

(Typical values are at $T_A=+25^\circ\text{C}$ unless otherwise noted, $\overline{\text{RESET}}$ or $\overline{\text{RESET}}$ open.)

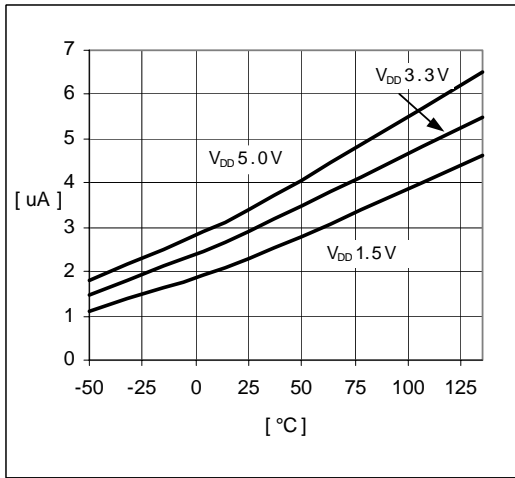

I_{DD} vs. Temperature

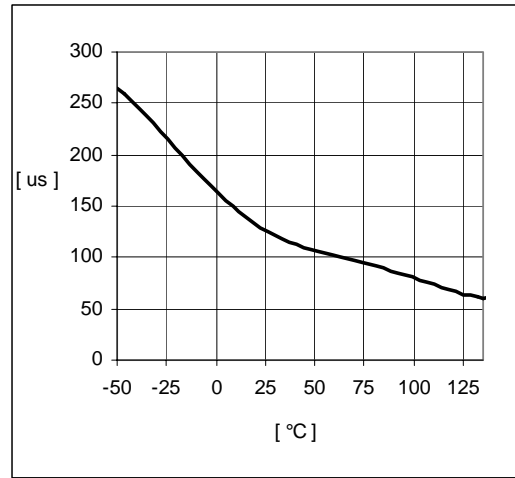

Propagation Time t_p vs. Temperature

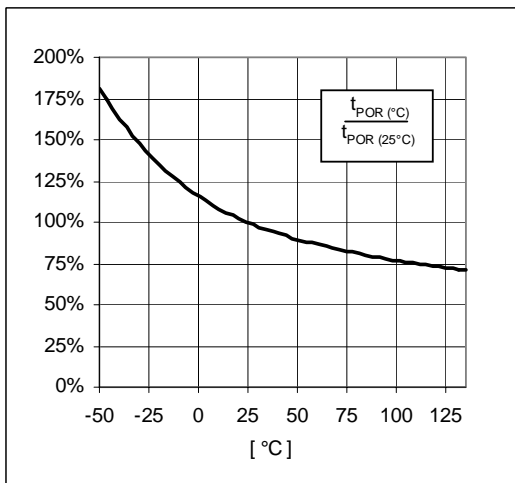

Reset Timeout Period t_{POR} vs. Temperature (normalized with respect to $t_{POR} 25^\circ\text{C}$)

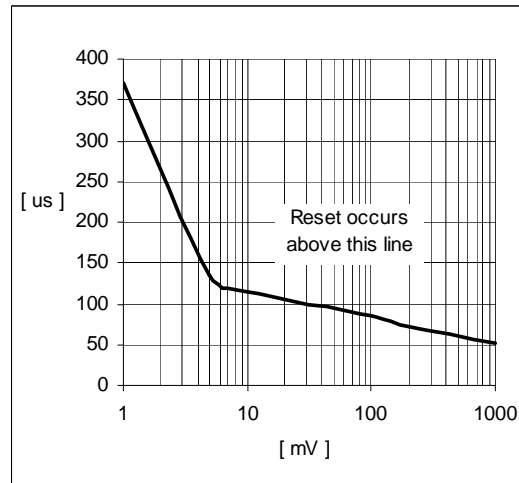

Maximum Transient Duration t_{SEN} vs. Overdrive $V_{TH} - V_{DD}$

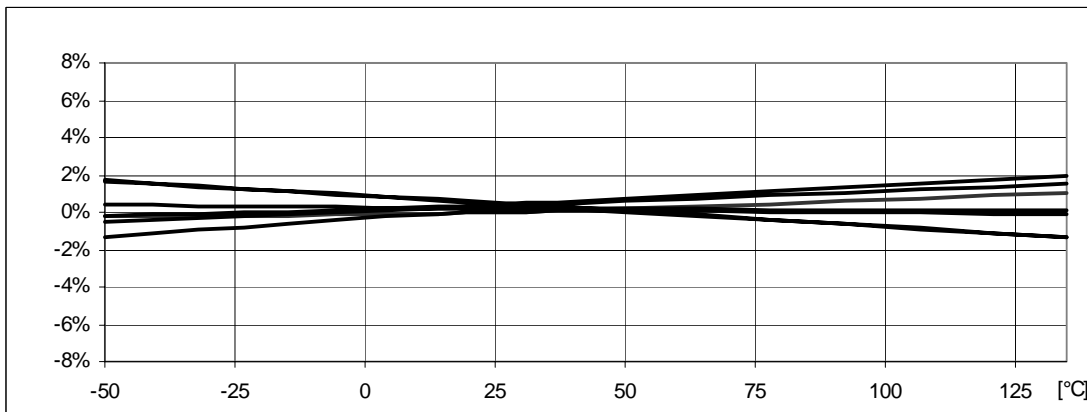

Threshold Voltage Variation vs. Temperature (normalized)

Package Information

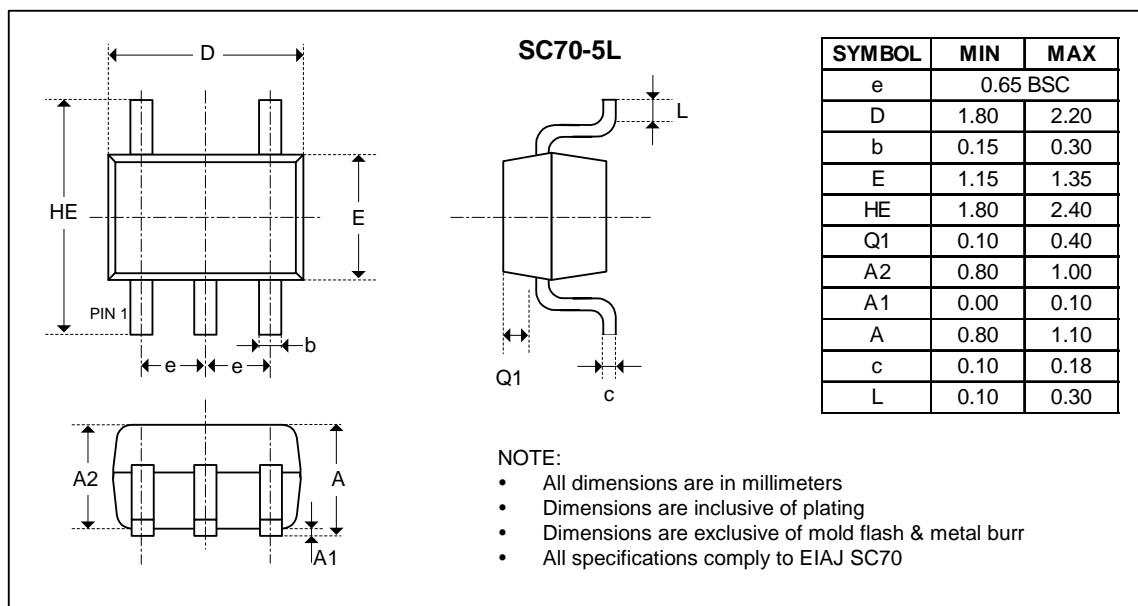
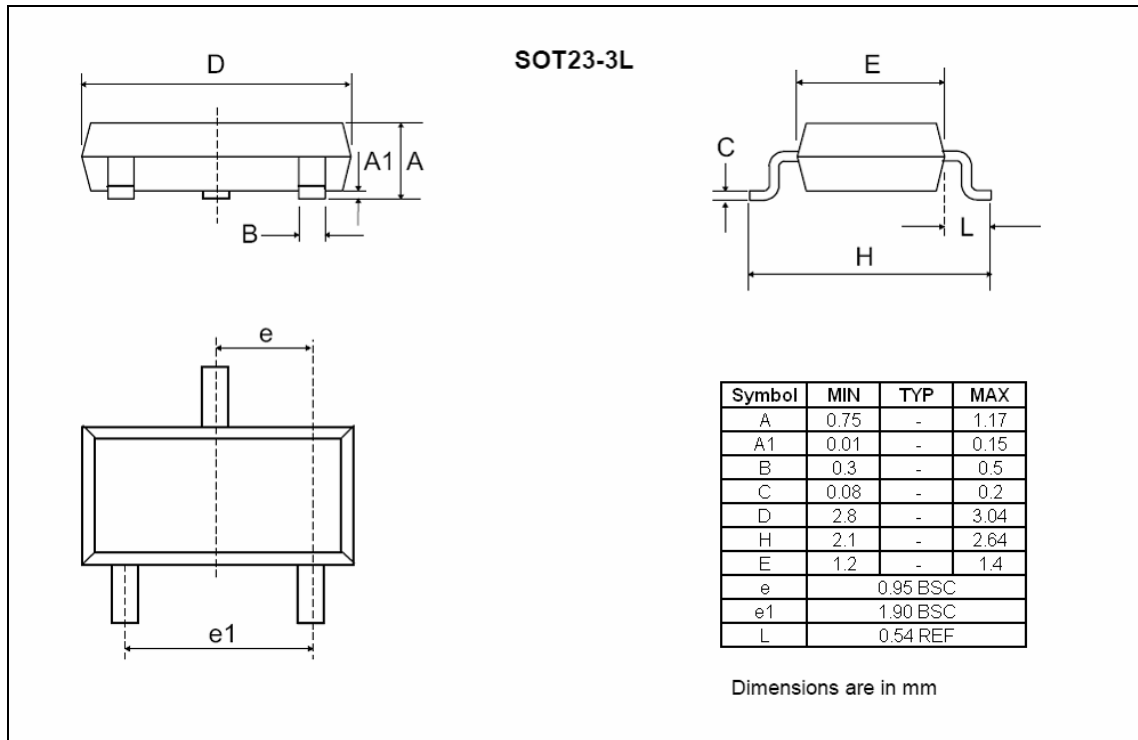

Traceability for small packages

Due to the limited space on the package surface, the bottom marking contains a limited number of characters that provide only partial information for lot traceability. Full information for complete traceability is however provided on the packing labels of the product at delivery from EM. It is highly recommended that the customer insures full lot traceability of EM product in his final product.

EM Microelectronic-Marín SA (EM) makes no warranty for the use of its products, other than those expressly contained in the Company's standard warranty which is detailed in EM's General Terms of Sale located on the Company's web site. EM assumes no responsibility for any errors which may appear in this document, reserves the right to change devices or specifications detailed herein at any time without notice, and does not make any commitment to update the information contained herein. No licenses to patents or other intellectual property of EM are granted in connection with the sale of EM products, expressly or by implications. EM's products are not authorized for use as components in life support devices or systems.

Product qualification is performed according to internal EM quality standards for industrial products. For any special requirement (eg. automotive grade) please contact EM Microelectronic-Marín S.A.