

Voltage Detector, High-Precision

Description

The EM6352 is an ultra-low current voltage detector available in a large variety of configurations and very small packages for maximum flexibility in all end-applications up to 125°C and using power supplies between 1.5V and 5.5V.

This circuit monitors the supply voltage of any electronic system, and generates the appropriate reset signal without a delay time. The threshold defines the minimum allowed voltage which guarantees the good functionality of the system. As long as V_{DD} stays above the threshold voltage, the output stays inactive. If V_{DD} drops below V_{TH} , the output goes active. The output is guaranteed to be in the correct state for V_{DD} down to 0.8V. There are 12 reset threshold voltages starting as low as 1.31V and up to 4.63V. The EM6352 features three output types: active-low push-pull, active-low open-drain and active-high push-pull.

Small SC70 and SOT23 packages as well as ultra-low supply current of 2.7µA make the EM6352 an ideal choice for portable and battery-operated devices.

Features

- ❑ Ultra-low supply current of 2.7µA ($V_{DD}=3.3V$)
- ❑ Operating temperature range: -40°C to +125°C
- ❑ ±1.5% reset threshold accuracy
- ❑ 12 reset threshold voltages V_{TH} : 4.63V, 4.4V, 3.08V, 2.93V, 2.63V, 2.26V, 2.2V, 1.8V, 1.66V, 1.57V, 1.38V, 1.31V
- ❑ 3 reset output options:
 - Active-low \overline{RESET} push-pull
 - Active-low \overline{RESET} open-drain
 - Active-high $RESET$ push-pull
- ❑ No external components
- ❑ Immune to short negative V_{DD} transients
- ❑ Guaranteed Reset valid down to 0.8V
- ❑ Threshold hysteresis: 2.1% of V_{TH}
- ❑ Very small SOT23-5L, SOT23-3L, SC70-3L packages

Typical Application

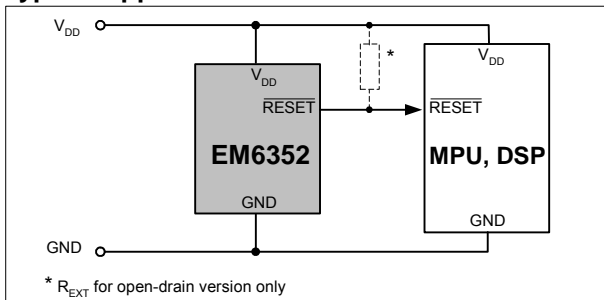

Applications

- ❑ Mobile and cordless phones
- ❑ Modems
- ❑ Printers
- ❑ TV, VCR, Video sets
- ❑ GPS
- ❑ Toys
- ❑ Basestations
- ❑ NiCd cell battery

Pin Configuration (top view)

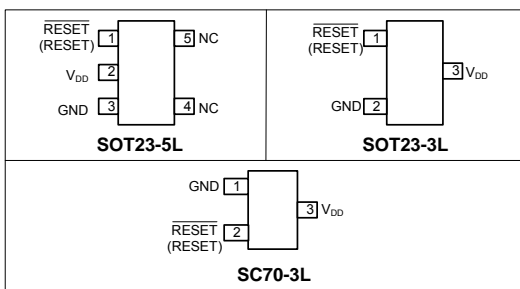

Block Diagram

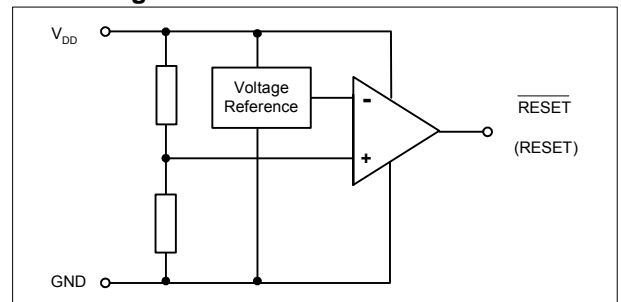

Pin Description

Pin			Name	Function
SOT23-5L	SOT23-3L	SC70-3L		
1	1	2	\overline{RESET}	Active-low \overline{RESET} output. \overline{RESET} remains low while V_{DD} is below the reset threshold voltage.
			RESET	Active-high RESET output. RESET remains high while V_{DD} is below the reset threshold voltage.
2	3	3	V_{DD}	Supply Voltage (5.5V max.)
3	2	1	GND	Ground
4, 5	-	-	N.C.	Not connected. Not internally connected



Ordering Information

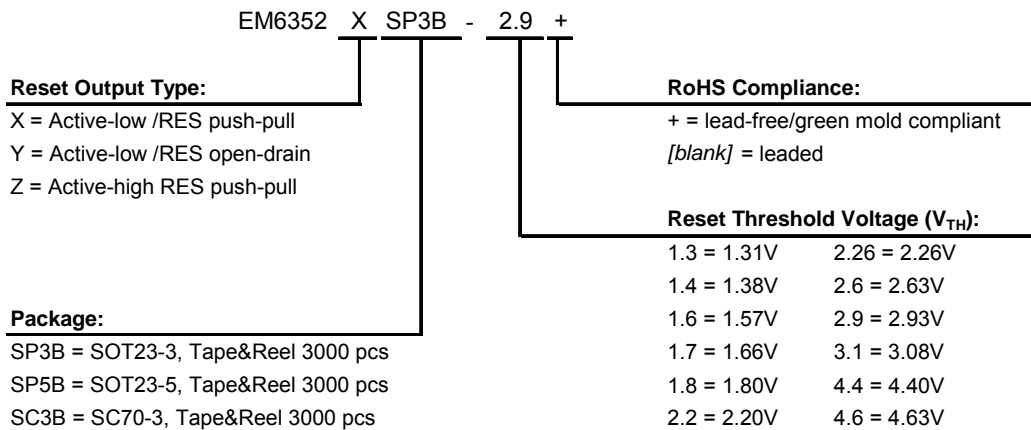

Note: subject to availability (see standard versions list below). Please give complete Part Number when ordering.

Standard Versions (Top Marking)

Part Number	Top Marking ¹⁾	Top Marking ²⁾ With 4 Characters
EM6352YSC3B-2.6+ EM6352XSP3B-4.6+ EM6352XSP3B-2.9+	KE## K8##	BKAT
EM6352XSP3B-2.6+ EM6352XSP3B-2.26+ EM6352XSP3B-2.2+	K7## K5##	BKAG
EM6352XSC3B-4.6+ EM6352XSC3B-2.9+ EM6352XSC3B-2.2+	K8## K5##	BKAL

- 1) Top marking is the standard from 2006. No bottom marking exists. Where ## refers to the lot number (EM internal reference only)
- 2) Top marking with 4 characters is standard from 2003. For lead-free/green mold (RoHS) parts, the first letter of top marking with 4 characters begins with letter "B" instead of letter "A". Bottom marking indicates the lot number.

Standard Versions (Samples)

Part Number
EM6352YSC3B-2.6+
EM6352XSP3B-4.6+
EM6352XSP3B-2.9+
EM6352XSP3B-2.6+
EM6352XSP3B-2.26+

Part Number
EM6352XSP3B-2.2+
EM6352XSC3B-4.6+
EM6352XSC3B-2.9+
EM6352XSC3B-2.2+

Sample stock is generally held on **standard versions** only. Please contact factory for other versions not shown here and for availability of non standard versions.



Absolute Maximum Ratings

Parameter	Symbol	Conditions
Voltage at V _{DD} to GND	V _{DD}	-0.3V to +6V
Minimum voltage at any signal pin	V _{MIN}	GND - 0.3V
Maximum voltage at any signal pin	V _{MAX}	V _{DD} + 0.3V
Electrostatic discharge max. to MIL-STD-883C method 3015.7 with ref. to V _{SS}	V _{ESD}	2000V
Max. soldering conditions	T _{MAX}	250°C x 10s
Storage Temperature Range	T _{STG}	-65°C to +150°C

Stresses above these listed maximum ratings may cause permanent damages to the device. Exposure beyond specified operating conditions may affect device reliability or cause malfunction.

Handling Procedures

This device has built-in protection against high static voltages or electric fields; however, anti-static precautions must be taken as for any other CMOS component. Unless otherwise specified, proper operation can only occur when all terminal voltages are kept within the voltage range. Unused inputs must always be tied to a defined logic voltage level.

Operating Conditions

Parameter	Symbol	Min	Max	Unit
Supply voltage (note 1)	V _{DD}	0.8	5.5	V
Operating Temperature	T _A	-40	+125	°C

Electrical Characteristics

Unless otherwise specified: V_{DD} = 0.8V to 5.5V, T_A = +25°C (note 1).

Parameter	Symbol	Conditions	Min	Typ	Max	Unit	
Supply current (note 2)	I _{DD}	V _{DD} =1.5V	+25°C	-	2.1	4.5	μA
			-40°C to +125°C	-		7	
		V _{DD} =3.3V	+25°C	-	2.7	5.4	
			-40°C to +125°C	-		8.3	
		V _{DD} =5.0V	+25°C	-	3.2	6.3	
			-40°C to +125°C	-		9.6	
Threshold voltage (note 3)	V _{TH}	EM6352 – 1.3	1.290	1.31	1.330	V	
		EM6352 – 1.4	1.359	1.38	1.401		
		EM6352 – 1.6	1.546	1.57	1.594		
		EM6352 – 1.7	1.635	1.66	1.685		
		EM6352 – 1.8	1.773	1.80	1.827		
		EM6352 – 2.2	2.167	2.20	2.233		
		EM6352 – 2.26	2.226	2.26	2.294		
		EM6352 – 2.6	2.591	2.63	2.669		
		EM6352 – 2.9	2.886	2.93	2.974		
		EM6352 – 3.1	3.034	3.08	3.126		
EM6352 – 4.4	4.334	4.40	4.466				
EM6352 – 4.6	4.561	4.63	4.699				
Threshold voltage temperature coefficient (note 4)	$\frac{\Delta V_{TH}}{\Delta T_A}$	T _A = -40°C to +125°C	-	±50	-	ppm/°C	
Threshold hysteresis	V _{HYS}		-	2.1%·V _{TH}	-	V	

Note 1: Production tested at +25°C only. Over temperature limits are guaranteed by design, not production tested. V_{DD} min=0.9V for active-high versions (EM6352Z).

Note 2: RESET (RESET) open.

Note 3: Threshold voltage is specified for V_{DD} falling.

Note 4: Typical variation ΔV_{TH} of V_{TH} at a given temperature T_A is calculated as follows:

$$\Delta V_{TH}(T = T_A) = \frac{\Delta V_{TH}}{\Delta T_A} \times V_{TH} \times |T_A - 25^\circ\text{C}|$$

Example:

for version V_{TH}=2.93V, variation at T_A=70°C is equal to ΔV_{TH}(70°C)=±50·10⁻⁶ x 2.93 x (70-25)=±6.59mV

Electrical Characteristics (continued)

Unless otherwise specified: $V_{DD} = 0.8V$ to $5.5V$, $T_A = +25^\circ C$ (note 1).

Parameter	Symbol	Conditions	Min	Typ	Max	Unit		
Reset timeout period	t_{POR}	V_{DD} from $0V$ to $V_{TH (typ)} + 15\%$ (note 2)	9	500	1090	μs		
Propagation delay time V_{DD} to \overline{RESET} (RESET) delay	t_p	V_{DD} drops from $V_{TH (typ)} + 0.2V$ to $V_{TH (typ)} - 0.2V$ (note 2)	2	130	255	μs		
Open-drain \overline{RESET} output Voltage	V_{OL}	$-40^\circ C$ to $+125^\circ C$	$V_{DD} > 1V$	$I_{OL} = 100\mu A$	-	-	0.3	V
			$V_{DD} > 2.5V$	$I_{OL} = 1.5mA$	-	-	0.3	
			$V_{DD} > 5V$	$I_{OL} = 3mA$	-	-	0.3	
Push-pull RESET / \overline{RESET} Output voltage	V_{OL}	$-40^\circ C$ to $+125^\circ C$	$V_{DD} > 1V$	$I_{OL} = 100\mu A$	-	-	0.3	V
			$V_{DD} > 2.5V$	$I_{OL} = 1.5mA$	-	-	0.3	
			$V_{DD} > 5V$	$I_{OL} = 3mA$	-	-	0.3	
	V_{OH}	$-40^\circ C$ to $+125^\circ C$	$V_{DD} > 1V$	$I_{OH} = -30\mu A$	0.8	-	-	
			$V_{DD} > 2.5V$	$I_{OH} = -1.5mA$	2	-	-	
			$V_{DD} > 5V$	$I_{OH} = -3mA$	4	-	-	
Output leakage current	I_{LEAK}	$-40^\circ C$ to $+125^\circ C$, only for EM6352Y (open-drain)	-	-	0.5	μA		

Note 1: Production tested at $+25^\circ C$ only. Over temperature limits are guaranteed by design, not production tested.
 $V_{DD \text{ min}} = 0.9V$ for active-high version (EM6352Z).

Note 2: \overline{RESET} (RESET) open.

Timing Waveforms

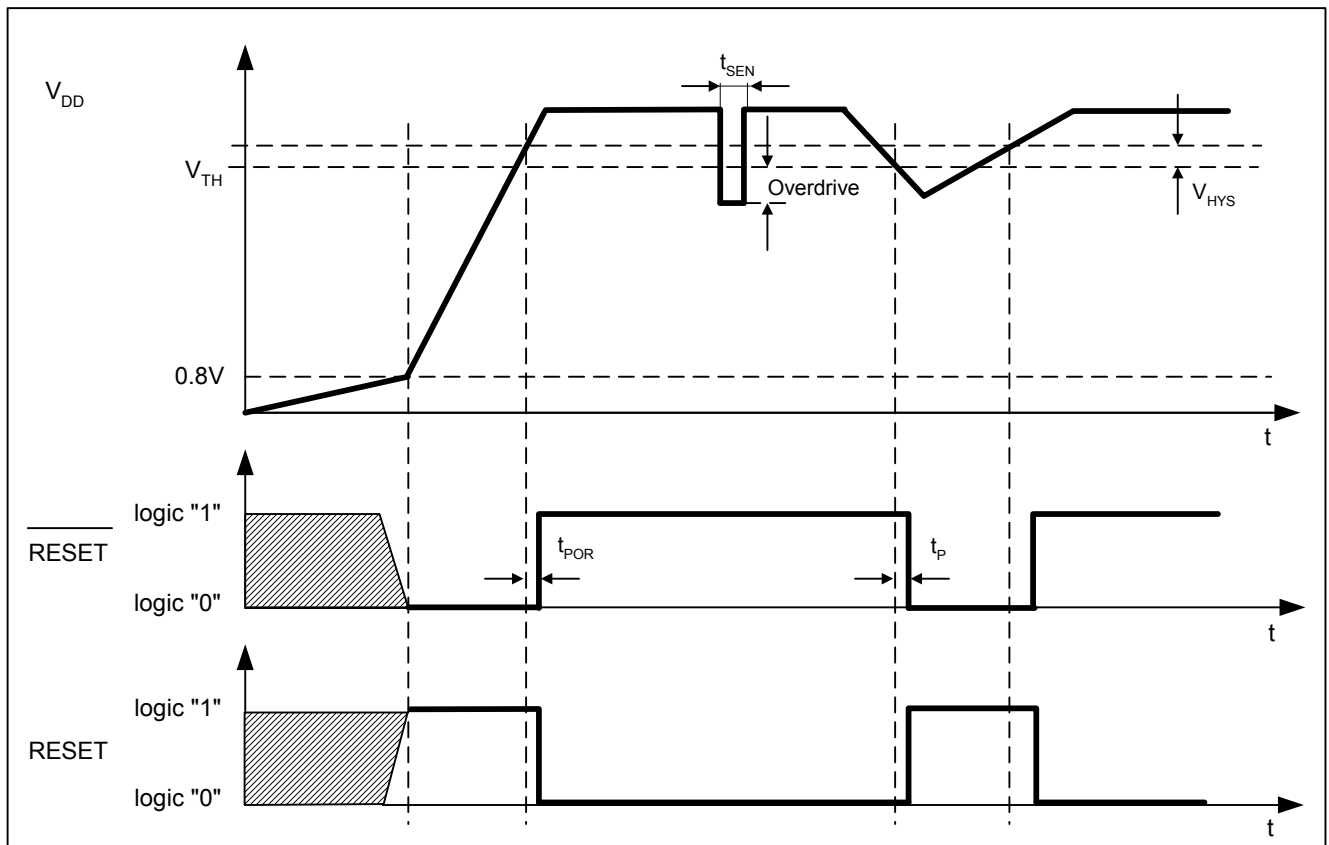

Note 5: t_{SEN} = Maximum Transient Duration. Please refer to figure on next page.

Note 6: Overdrive = $V_{TH} - V_{DD}$. Please refer to figure on next page.

Typical Operating Characteristics

(Typical values are at $T_A=+25^\circ\text{C}$ unless otherwise noted, $\overline{\text{RESET}}$ or RESET open.)

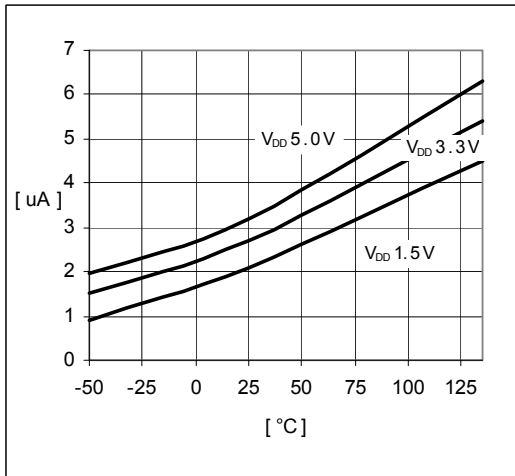

I_{DD} vs. Temperature

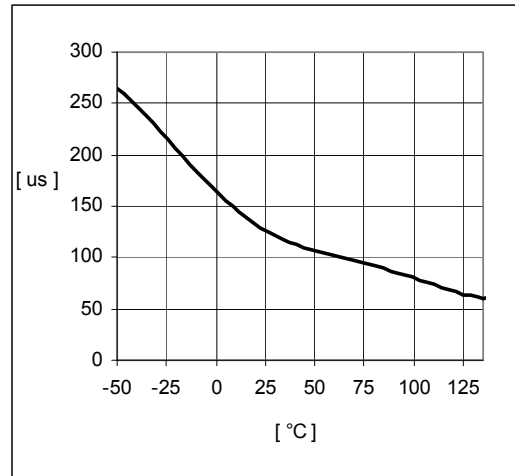

Propagation Time t_P vs. Temperature

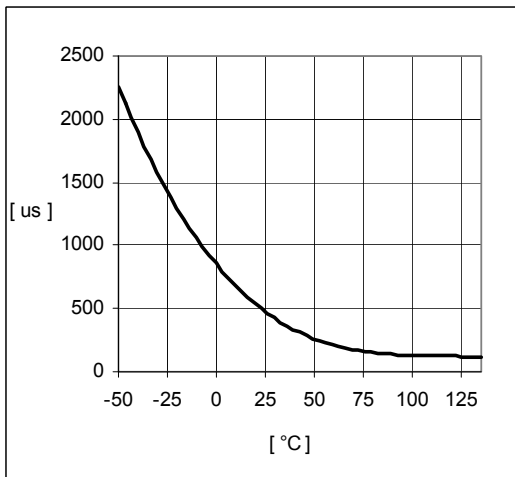

Reset Timeout Period t_{POR} vs. Temperature

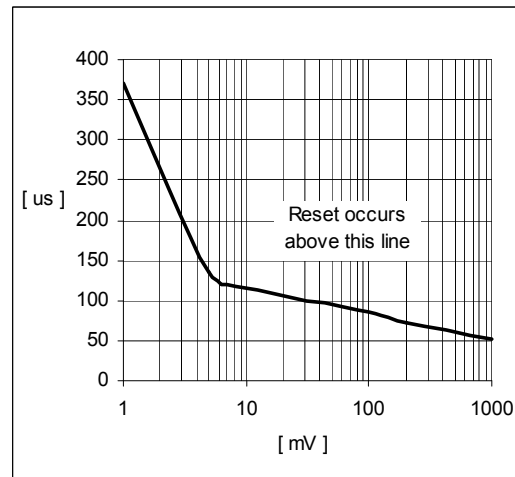

Maximum Transient Duration t_{SEN} vs. Overdrive $V_{TH} - V_{DD}$

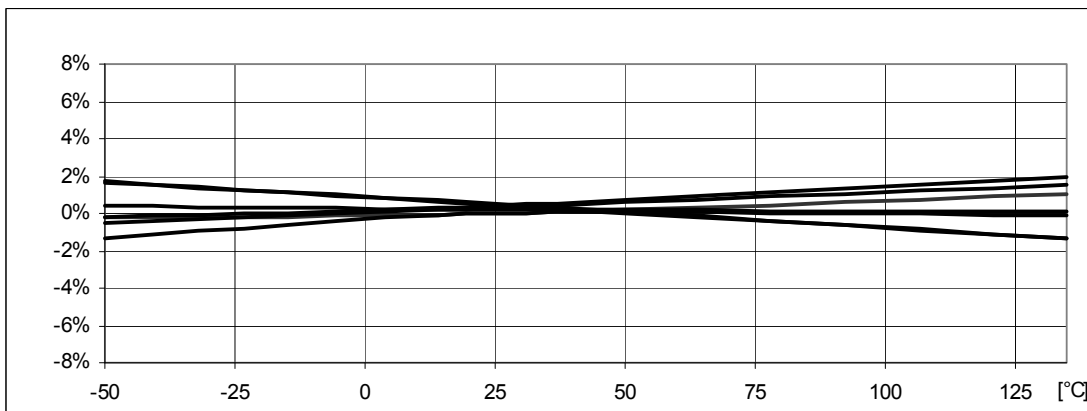

Threshold Voltage Variation vs. Temperature (normalized)

Package Information

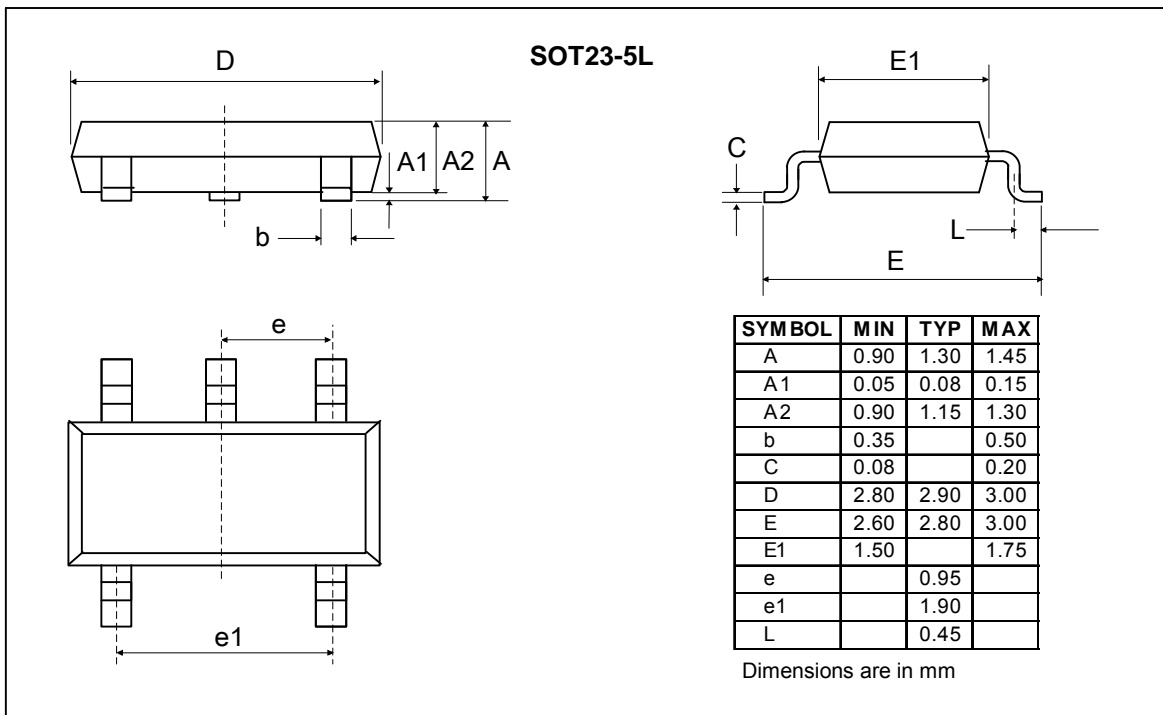
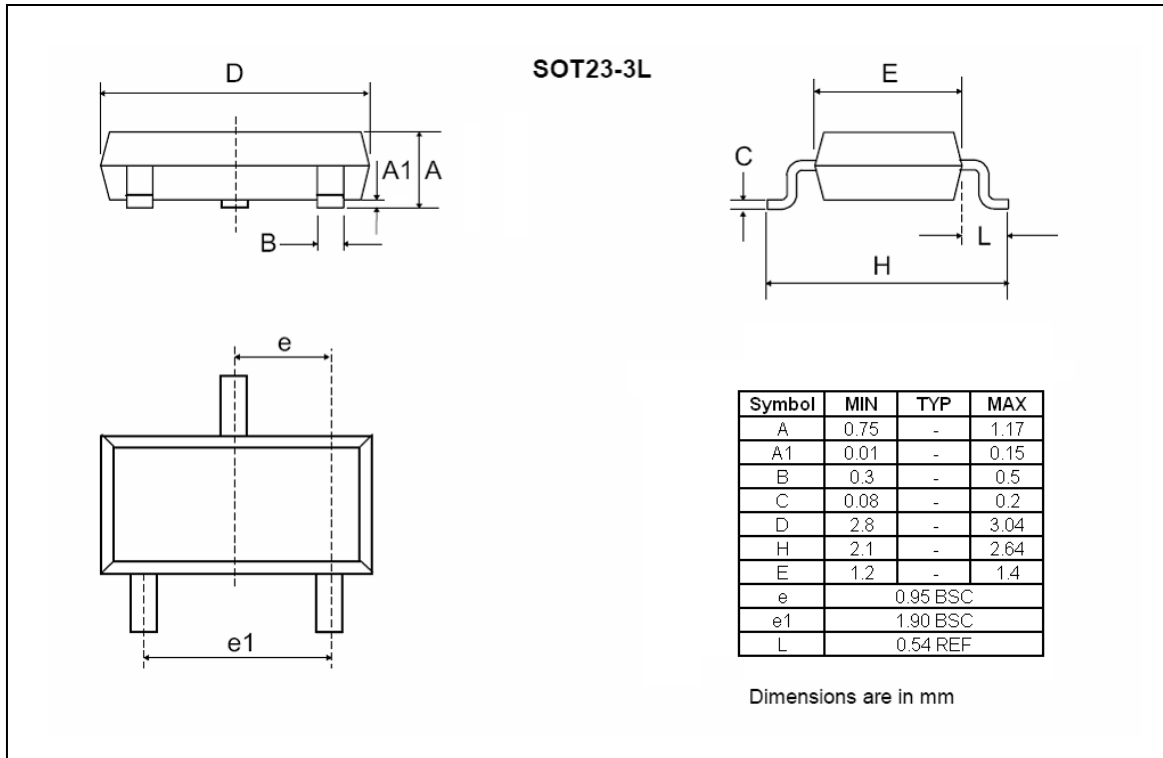

Package Information (continued)

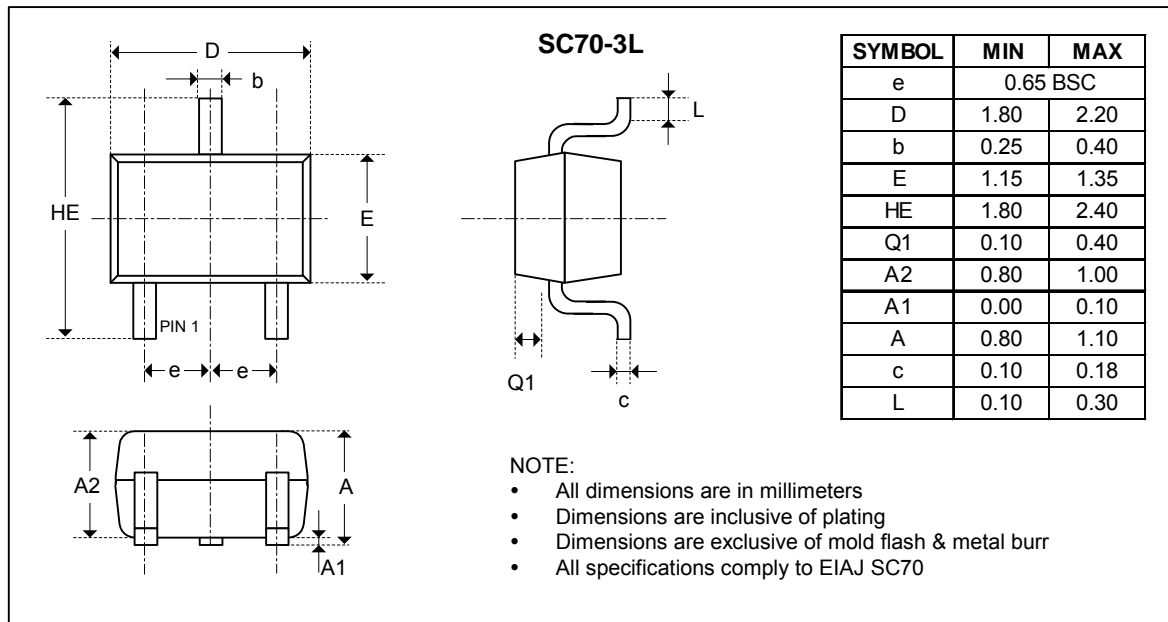

Traceability for small packages

Due to the limited space on the package surface, the bottom marking contains a limited number of characters that provide only partial information for lot traceability. Full information for complete traceability is however provided on the packing labels of the product at delivery from EM. It is highly recommended that the customer insures full lot traceability of EM product in his final product.

EM Microelectronic-Marin SA (EM) makes no warranty for the use of its products, other than those expressly contained in the Company's standard warranty which is detailed in EM's General Terms of Sale located on the Company's web site. EM assumes no responsibility for any errors which may appear in this document, reserves the right to change devices or specifications detailed herein at any time without notice, and does not make any commitment to update the information contained herein. No licenses to patents or other intellectual property of EM are granted in connection with the sale of EM products, expressly or by implications. EM's products are not authorized for use as components in life support devices or systems.

Product qualification is performed according to internal EM quality standards for industrial products. For any special requirement (eg. automotive grade) please contact EM Microelectronic-Marin S.A.