



TIM-4R

ANTARIS[®] 4 Programmable GPS Module with Dead Reckoning Automotive Applications

Preliminary Data – Scheduled for Q2 2007

Overview

The TIM-4R is a dead reckoning GPS module powered by the 16-channel ANTARIS 4 engine. Dead reckoning works by combining GPS satellite position data, gyroscope data (that measures angle turns) and odometer data (that measures distance covered) to calculate a position. This enables accurate navigation in locations with poor or lacking GPS such as tunnels, indoor parking facilities and deep urban canyons. This makes the TIM-4R the ideal solution for applications requiring an accurate positioning solution that provides road coverage positioning 100% of the time.



25.4 x 25.4 x 3 mm

The innovative Enhanced Kalman Filter algorithm uses a combination of GPS and sensor data where the weighting depends on the quality of the GPS signals. Particularly in deep urban canyons, positioning errors resulting from poor signals are effectively mitigated by dead reckoning.

Block Diagram

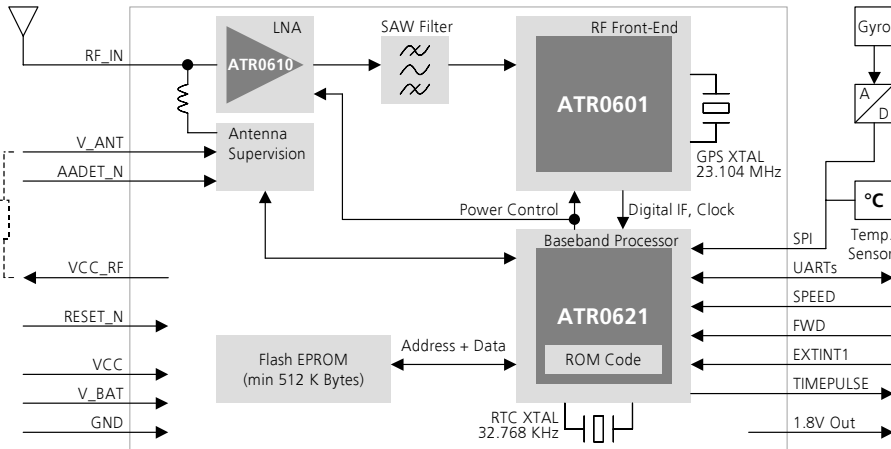

Highlights

- **100% coverage:**
Continuous position fixes even in tunnels
- **Accurate and reliable navigation performance**
- **Automatic sensor calibration and temperature compensation**
- **Supports A-GPS services including AssistNow[®] Online**
- **2 UART ports**

Features

- 16 channel ANTARIS 4 positioning engine
- 40 Hz dead reckoning calculation rate
- Flash EPROM inside
- Power saving modes
- 5 μ A backup current
- Supports passive and active antennas
- Antenna short and open circuit detection and protection
- Power brown-out protection:
No external reset hardware needed
- Operating temperature range: -40 to 85°C
- RoHS compliant (lead-free)

*your position
is our focus*



Receiver Performance Data

Receiver Type	16 channel, L1 frequency, C/A code	
Max. Update Rate	1 Hz	
Accuracy	Position	2.5 m CEP
	DGPS	2.0 m CEP ¹
Start-up Times	Hot start	<3.5 sec
	Warm start	33 sec
	Cold start	34 sec
	Aided start	5 sec
	Reacquisition	< 1 s
Sensitivity	Acquisition	-140 dBm
	Tracking	-150 dBm
Timing Accuracy	RMS	50 ns
	99%	<100 ns
Operational Limits	Altitude	18,000 m
	Velocity	515 m/s
	One of the limits may be exceeded but not both.	

¹ Depends on accuracy of correction data provided by the DGPS service

Dead Reckoning Performance Data

DR Calculation Rate	40 Hz ²	
Wheel tick input	Range:	1 to 2000 Hz

² Internal calculation rate for high accuracy in DR calculation. Not to be confused with maximum navigation update rate listed under Receiver Performance Data.

Interfaces

Serial Ports	2 UARTS	
SPI	Configured for specified A/D converters to receive gyroscope and temperature. ³	
Digital Input Ports	SPEED	Wheel pulse input
	FWD	Direction indicator
	EXTINT1	optional A-GPS time synchronization
Digital Output Ports	TIMEPULSE	Configurable time pulse signal (1PPS)
Serial, SPI and I/O Voltages	3 V levels, 5 V tolerant inputs	
Protocols	NMEA, UBX binary, RTCM	
	Supports protocol mixing over same serial port	

³ Please refer to the TIM-4R Data Sheet for information about supported gyroscopes, A/D converters and temperature sensors.

Electrical Data

Power Supply	2.7 to 3.3 V	
Power Consumption	typ. 48 mA @ 3.0 V	
	typ. 47 mA @ 2.7 V	
	Sleep mode: typ. 65 µA	
Backup Power	1.5 V to 3.6 V, typ. 5 µA	
Antenna Power	External or Internal VCC_RF	
Antenna Supervision	Integrated short-circuit detection and antenna shutdown, open circuit detection is supported with AADET_N input and little external circuitry	

Environmental Data

Operating Temp.	-40°C to 85°C
Storage Temp.	-40°C to 125°C
Vibration	5 Hz to 500 Hz, 5g (IEC 68-2-6)
Shock	Half sine 30g / 11ms (DIN 40046-7)

Mechanical Data

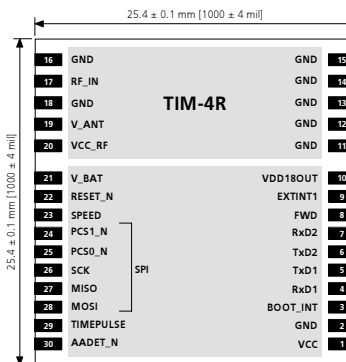

Support Products

AEK-4R (planned)	An easy-to-use kit to get familiarized with the ANTARIS 4 positioning technology and to evaluate functionality and to visualize GPS and dead reckoning performance. Gyroscope is included.
ANTARIS 4 GPS Dead Reckoning Evaluation Kit	

Ordering Information

TIM-4R-0-000-0	TIM-4R – Programmable GPS Module with Dead Reckoning
	Delivery Packing
	0 = Single samples
	1 = Tape on reel (100 pieces)

Semiconductor technology provided by ATMEL.